

# XTERRA // //

A division of Arrow Science and Technology LLC

## XCD-3U/6U HYBRID USER'S GUIDE

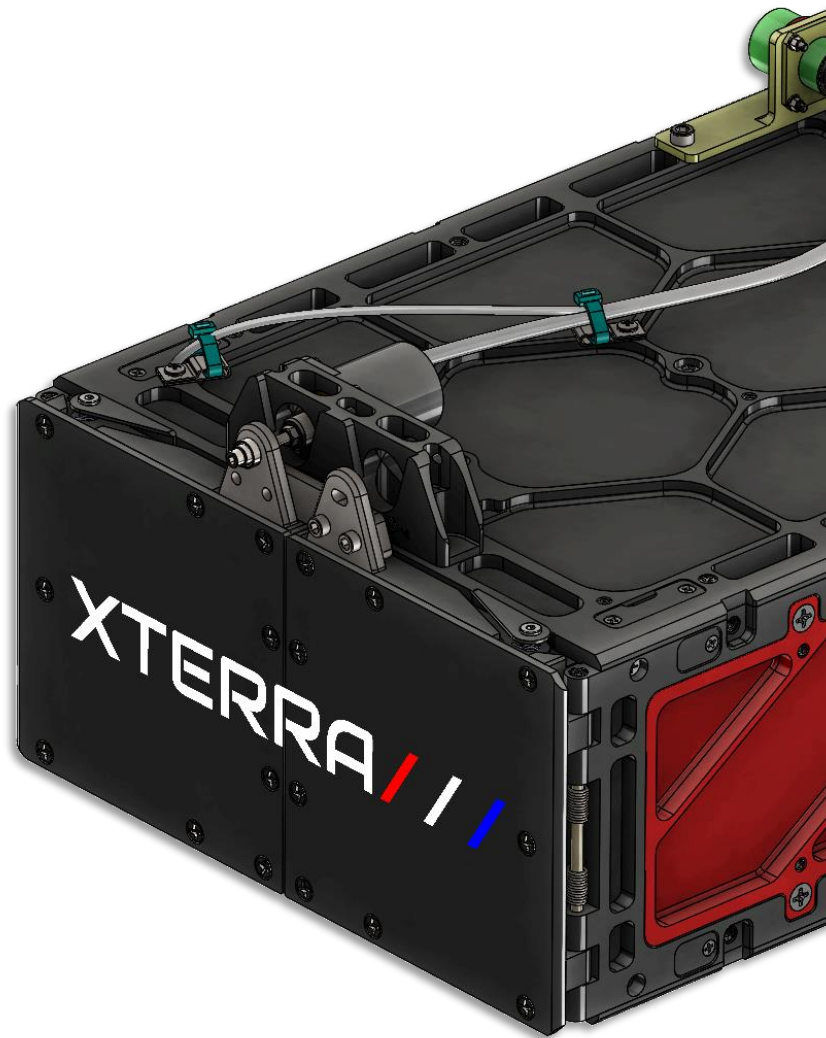

XTD-100084  
Revision 1.3

XTERRA and Arrow Science and Technology, LLC are the copyright owners in this work, and no portion herein is to be copied, reproduced, or disseminated without their prior written approval.

## REVISIONS

Rev	By	Date	Description
1.0	TH	1/20/23	Initial Release
1.1	TH	11/22/23	Updated Authors subject matter, CSD isolation linked, updated doc numbers, 2.0 real pictures added, 3.2 updated, 4.1 updated with increased CubeSat volume, 4.2 rail dims and requirements updated, 5.1 mass updated, general description updates throughout. Aft mounting scheme updated to be SpaceX Compatible. Electrical information updated.
1.2	TH	2/27/24	Updated section 4.2 rail end minimum, 4.4 activation switch locations, 6.2 clarified, added electrical guide DN to additional documentation section
1.3	TH & MR	4-10-25	Updated document to new standard configuration, entire document substantially overhauled.

## AUTHORS

Name	Subject Matter	Contact Information
Tyler Holden	Electrical, Mechanical & Deployment	<a href="mailto:tholden@xterra.space">tholden@xterra.space</a>
Mark Rowley	Mechanical Support	<a href="mailto:mrowley@arrowscitech.com">mrowley@arrowscitech.com</a>

Note: Looking for custom tweaks to this system? Need a wholly custom deployment solution? Contact authors above.

## ADDITIONAL INFORMATION

Source	Description
Cal Poly State University	<a href="#">Launch Isolation Vibration for CubeSat Dispenser</a>
XTERRA	<a href="https://www.xterra.space/">https://www.xterra.space/</a>

## ACRONYM DEFINITIONS

Acronym	Description
XCD	XTERRA CubeSat Dispenser
CG	Center of Gravity

## NEED A RIDE TO SPACE?

Name	Subject Matter	Contact Information
Marcia Hodge	Rideshare	<a href="mailto:mhodge@arrowscitech.com">mhodge@arrowscitech.com</a>
Space Logistics		<a href="https://www.arrowscitech.com/space-logistics">https://www.arrowscitech.com/space-logistics</a>

Note: This document is a work in progress and additional information will be added as it becomes available. Feedback sent to the authors is welcomed.

# TABLE OF CONTENTS

- 1. INTRODUCTION ..... 4
- 2. SYSTEM OVERVIEW ..... 5
- 3. UNIQUE DISPENSER FEATURES ..... 8
  - 3.1 CUSTOM SATELLITE LENGTHS ..... 8
  - 3.2 RAPID CONVERSION & MAXIMUM SATELLITE ACCESS ..... 8
- 4. SATELLITE FUNDAMENTALS ..... 9
  - 4.1 FORMATS AND DIMENSIONS ..... 9
  - 4.2 RAILS & ACCESS PANELS ..... 10
  - 4.3 DEPLOYABLE APPENDAGES ..... 10
  - 4.4 CG OFFSET ..... 10
  - 4.5 INHIBIT/ACTIVATION SWITCHES ..... 11
- 5. DISPENSER FUNDAMENTALS ..... 12
  - 5.1 MASS AND DIMENSIONS - STANDALONE DISPENSER ..... 12
  - 5.2 MASS AND DIMENSIONS - QUADPACK ..... 13
  - 5.3 AFT MOUNTING INTERFACE - STANDALONE & QUADPACK ..... 14
  - 5.4 FLIGHT ACCESS ..... 15
  - 5.5 CUSTOMER LOGOS ..... 15
  - 5.6 PRELOAD & RAIL INTERFACE ..... 15
  - 5.7 CONVERSION SPACERS ..... 16
  - 5.8 DOOR FEATURES & RAPID RESET ..... 16
  - 5.9 DISPENSER ACCESS AND CLAMSHELL ..... 17
  - 5.10 DEPLOYMENT CONFIRMATION ..... 18
  - 5.11 DEPLOYMENT DYNAMICS ..... 18
- 6. ELECTRICAL CHARACTERISTICS ..... 19

# 1. INTRODUCTION

XTERRA has designed and/or manufactured hardware that has successfully deployed over 350 satellites, has developed over 20 unique designs, and has been designing and building space hardware [since 2012](#). We design and manufacture cutting edge, electro-mechanical devices that change what you can do in space. Building on a legacy of success, the XTERRA CubeSat Dispenser (XCD) redefines deployment hardware with its flight proven, American-made design. With our patent-pending modular approach to CubeSat dispenser design, the XCD is designed to reduce costs, cut lead times, and remove pain points from traditional CubeSat dispenser offerings, while retaining the highest quality standards.

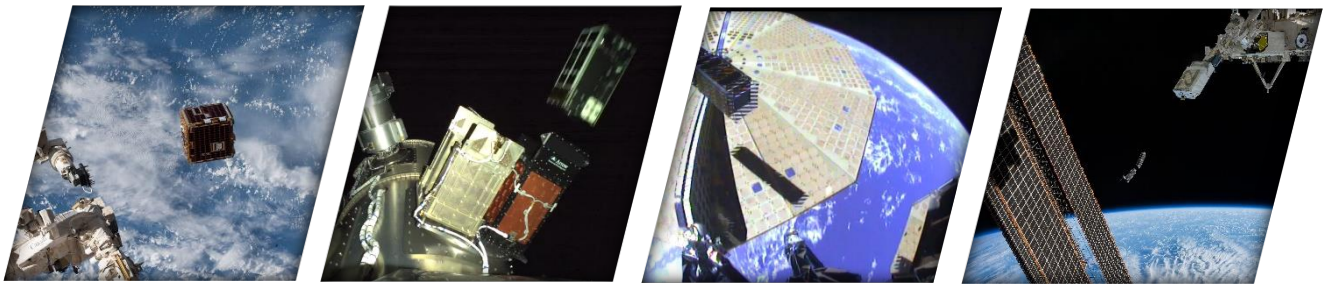

Users often need to purchase 3U or 6U dispensers separately to cover potential dimensional or manifesting changes that can occur prior to flight. This problem is exacerbated by the often-tight schedules typical of launch date driven projects which may result in a change to the manifest at the last second. Our system allows us to rapidly convert to custom length satellites you may want to fly, anything between 113.5m and 366mm. Additionally, the XCD can be converted between 3U and 6U satellite compatibility in about an hour. These conversion capabilities drastically decrease operational complexity. No more waiting months for a vendor to get a legacy dispenser converted or ordering a new dispenser at the last second.



The XCD is rapidly resettable, offers the most integrated satellite access on the market, allows rapid convertibility between different form factors, all supported by the reliable expertise that ensures customers' success every time.

No dispenser on the market rivals the flexibility or convenience of the XCD.

## 2. SYSTEM OVERVIEW

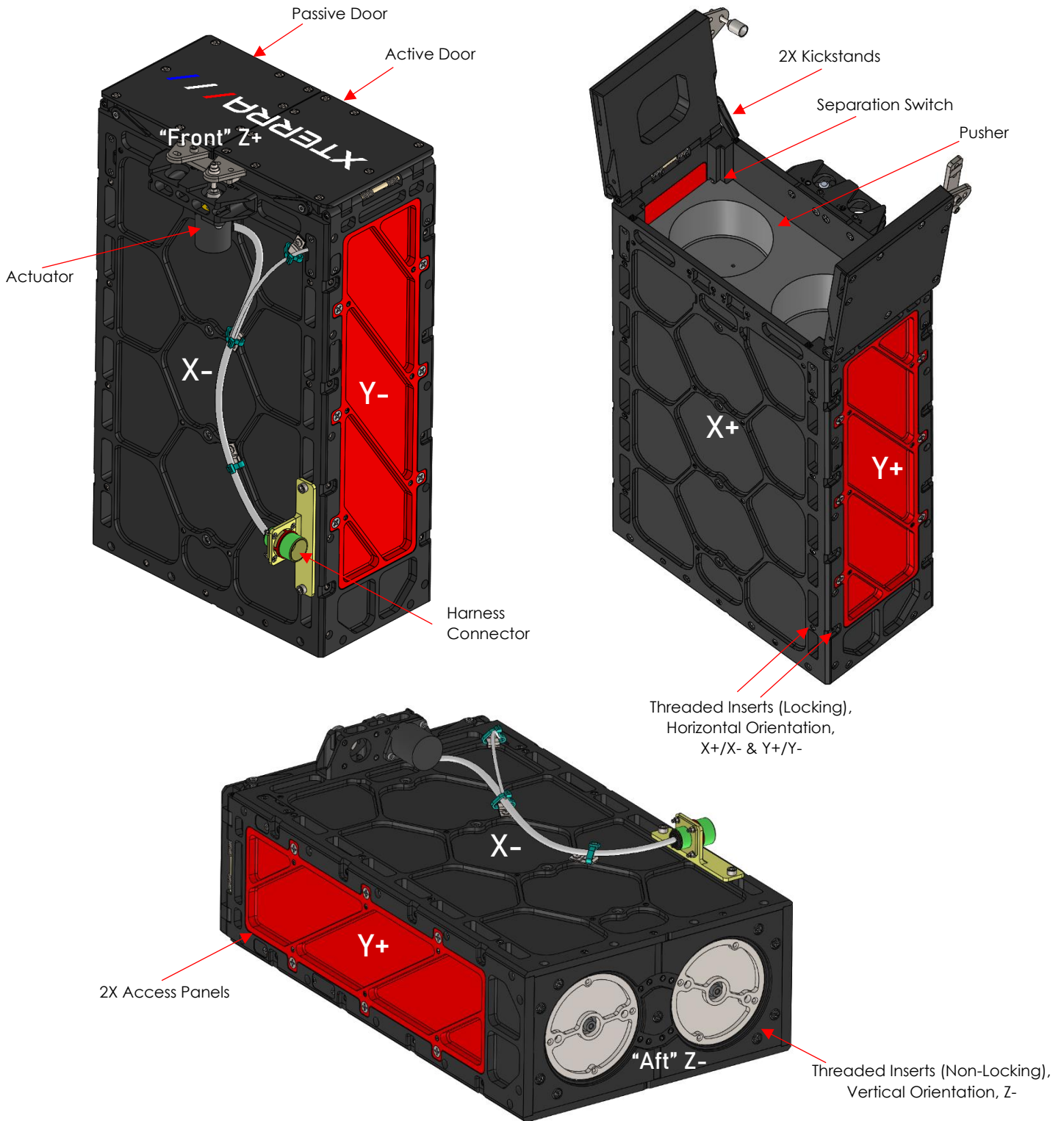
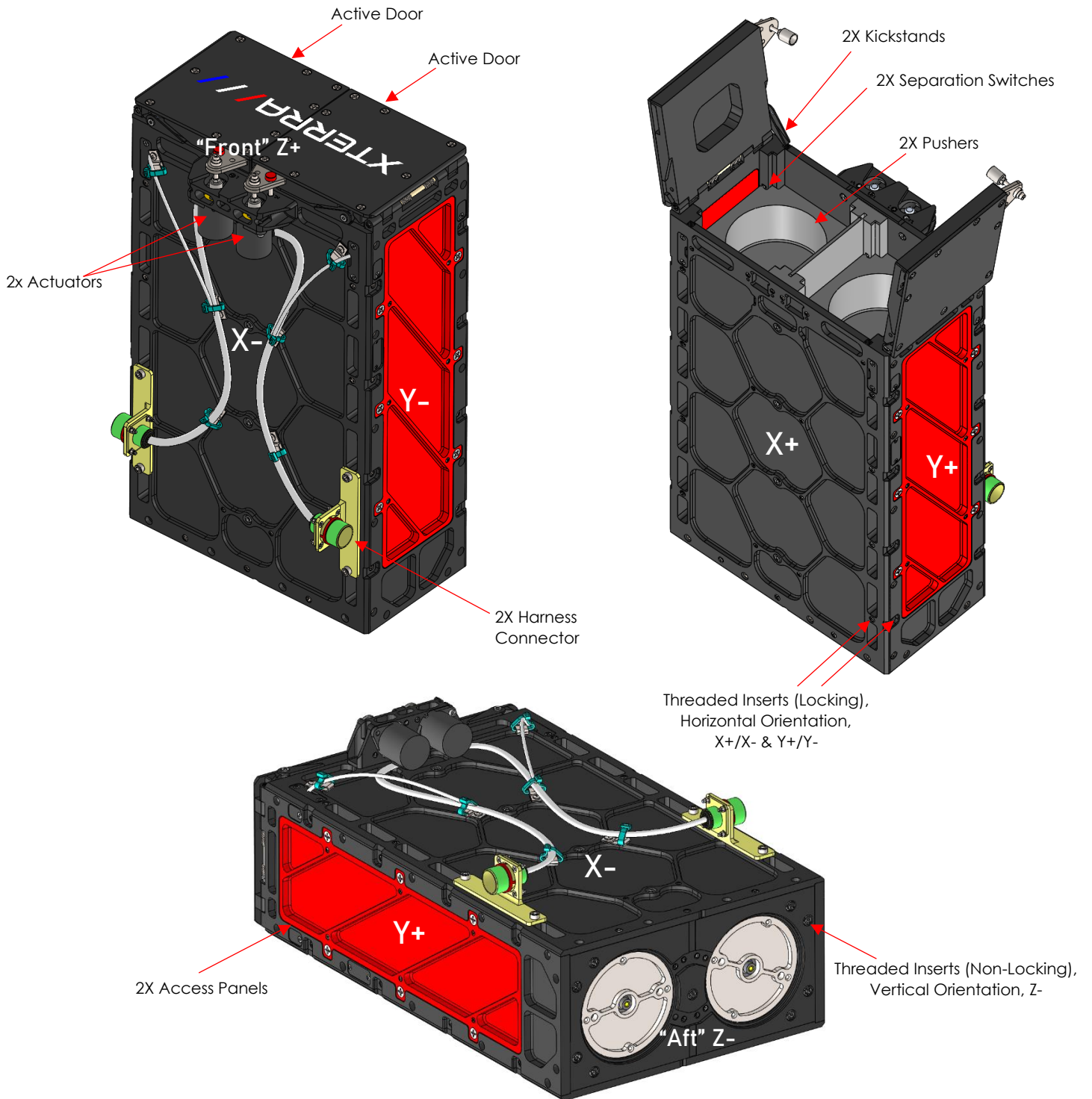

Figure 1: XCD 6U Configuration



**Figure 2: XCD 3U Configuration**

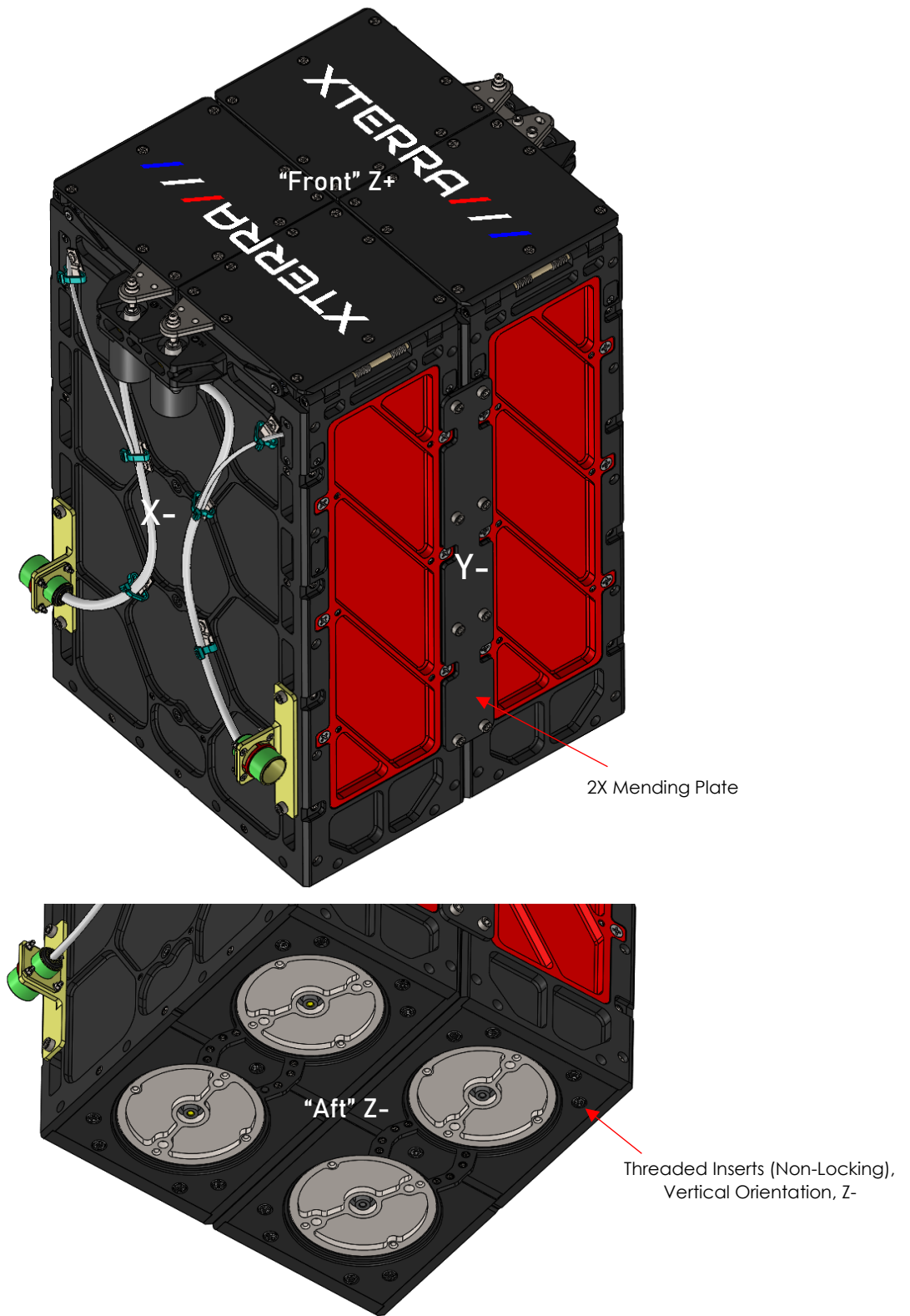

Figure 3: XCD-Quadpack Configuration

## 3. UNIQUE DISPENSER FEATURES

### 3.1 CUSTOM SATELLITE LENGTHS

Custom satellite spacers to accommodate standard and non-standard payload lengths have been radically simplified using the XCD. This new spacer design allows for very short lead time spacer at a tiny fraction of the cost of a traditional solution. While the spacers are installed, the dispenser components interfacing with the satellite do not change regardless of the satellite length. The result of this feature is this dispenser can be rapidly converted from a 366mm to a 113.5mm compatible tube in about an hour, or any length satellite in between. Inform XTERRA of your satellite length and we will deliver the dispenser preconfigured appropriately.

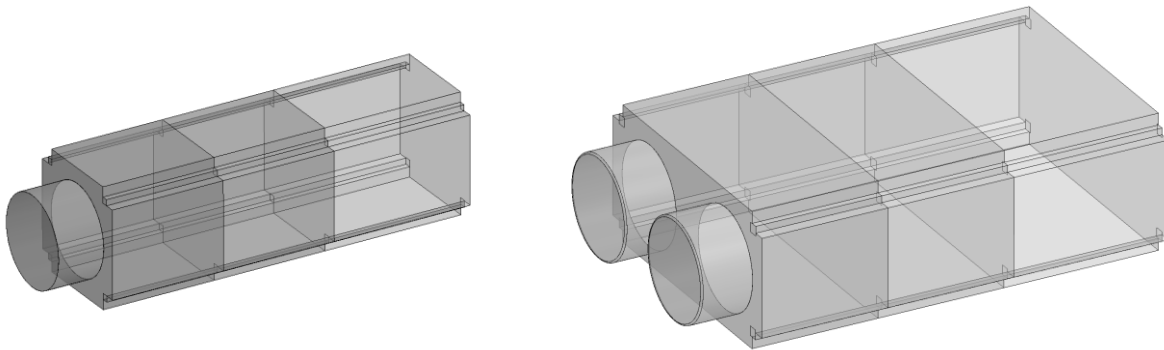

Figure 4: Custom Lengths

### 3.2 RAPID CONVERSION & MAXIMUM SATELLITE ACCESS

Users shouldn't have to order a brand-new dispenser if their customers have different satellite lengths or form factors. Nor should they need to wait months to convert an existing dispenser they have in stock. Time is crucial. With that in mind converting the XCD takes only an hour with minimal training and can support the industry standard 366mm maximum length CubeSat in either up to 3U or 6U form factor tubes. This feature also allows a satellite to be partially integrated with the clamshell portion of the dispenser removed for maximum surface exposure before final integration.

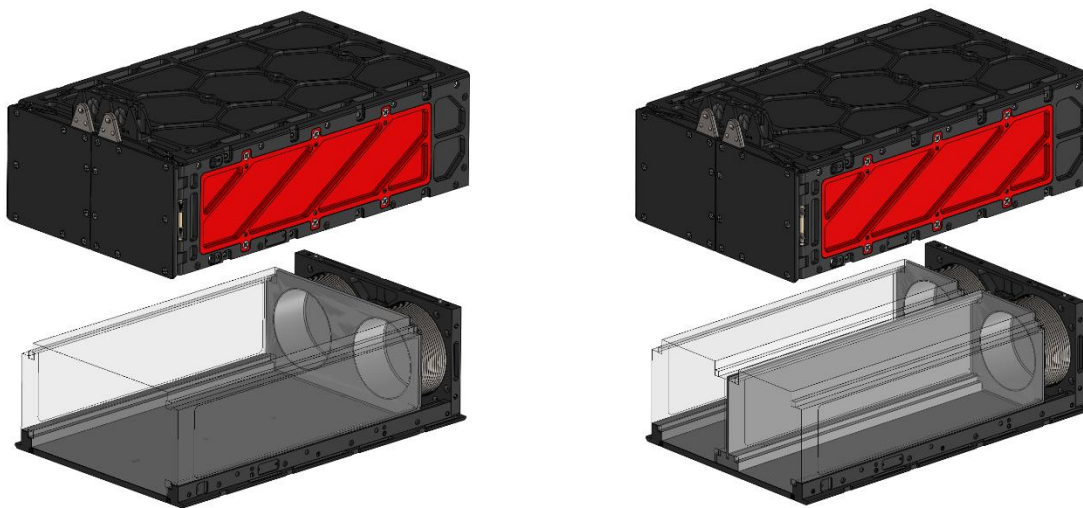

Figure 5: Clamshell



## 4. SATELLITE FUNDAMENTALS

### 4.1 FORMATS AND DIMENSIONS

The XCD houses up to a single 6U payload, while the 3U config houses up to two 3U payloads. The 3U config can have multiple 1U or 2U satellites stacked at any length if the stack height does not exceed the maximum allowable length per tube or impede deployment. The satellite shall not exceed the max volume shown in Figure 6 under dynamic testing and launch loads. Dimensions are in [mm] and inches.

1U	2U	3U	Satellite Format	2U	4U	6U
2.17	3.25	6.50	Mass (kg) Max	3.25	8.67	13.00
113.5Min	366	366 Max	Rail to Rail Length (mm) Z <sub>axis</sub>	113.5Min	227	366 Max

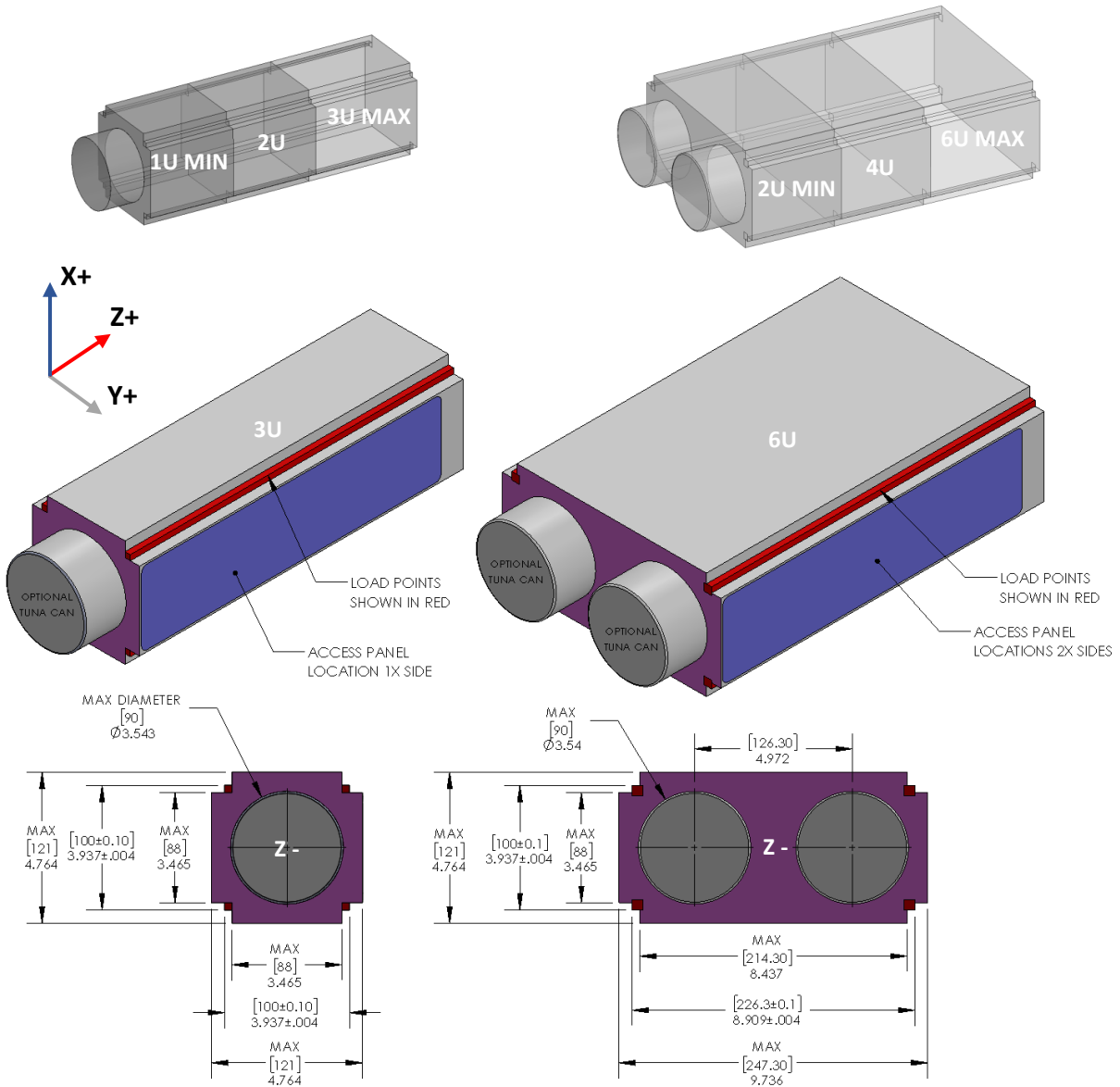

Figure 6: Satellite Volume

### 4.2 RAILS & ACCESS PANELS

CubeSats must have rails as shown in Figure 6 & 7 in red. These will directly interface with the dispenser rails during launch and will be the guiding surface during deployment. Noncontinuous rails may be acceptable pending an XTERRA review. Each CubeSat rail shall have a minimum width as shown in Figure 6. Front access panels can compress inhibit/activation switches.

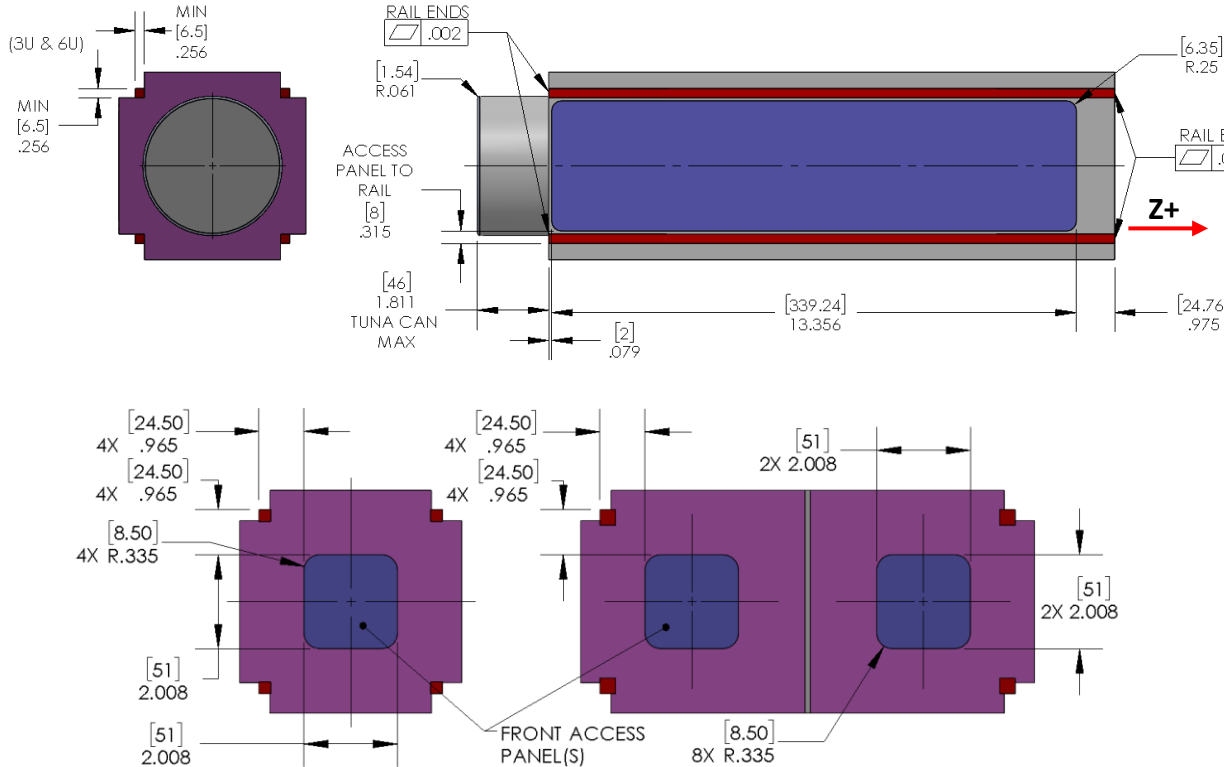

Figure 7: Rail profile, Volume Continued, Access Panel Locations

### 4.3 DEPLOYABLE APPENDAGES

It is highly recommended that any deployable satellite appendages are constrained through launch and during deployment. Appendages can be constrained by the dispenser during launch and deployment (if launch vehicle allows), but fit checks are highly recommended to ensure a reliable deployment using this method and an XTERRA review will be necessary.

### 4.4 CG OFFSET

It is recommended that the offset from the geometrical center of the satellite and the CG is limited to the values shown below. Higher values will result in greater tipoff during deployment.

Satellite	X-axis (mm)	Y-axis (mm)	Z-axis (mm)
1U	+/-20	+/-20	+/-20
3U	+/-20	+/-20	+/-70
6U	+/-20	+/-45	+/-70

Note: Offset scales roughly linearly in the Z-axis with regards to satellite lengths between 113.5mm and 366mm.

Note: Satellites with offsets that exceed the values above are compatible with this dispenser but must be reviewed.

### 4.5 INHIBIT/ACTIVATION SWITCHES

Switches, which activate the satellite after deployment, may be positioned anywhere compression is guaranteed between the satellite and the dispenser. Typically, there are switches on the ends of the rails in the Z axis or on the Z faces of the satellite, activation travel recommended .75mm MIN. Switches can also be along sides of the rails in the X or Y axis. The X & Y axis switches must have enough travel to guarantee switch compression, 1.5mm travel minimum. See Figure 8. A simplified dispenser CAD model can be provided for a digital fit check to ensure that switches will compress as desired.

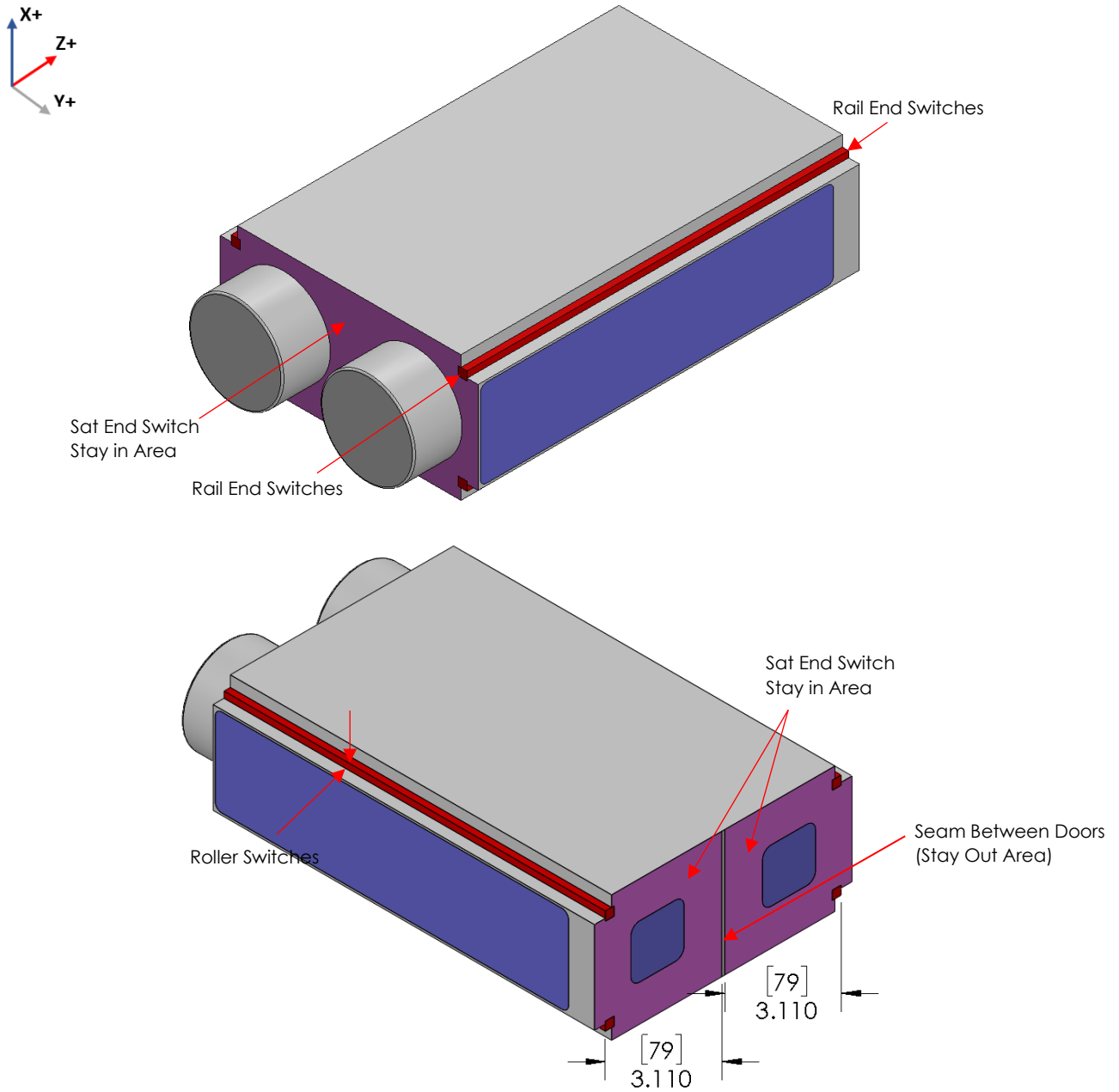

**Figure 8: Switch general locations**

## 5. DISPENSER FUNDAMENTALS

### 5.1 MASS AND DIMENSIONS - STANDALONE DISPENSER

External dimensions for the dispenser, in any internal configuration, are the same. Top Y+ face and bottom Y- face threaded features are mirrored on both sides. Right X- face and left X+ face threaded features are mirrored on both sides. Connectors are facing the Y-/Y+ face of the dispenser as shown.

Configuration	3U	6U
Empty Dispenser Mass (kg)	7.25	6.50

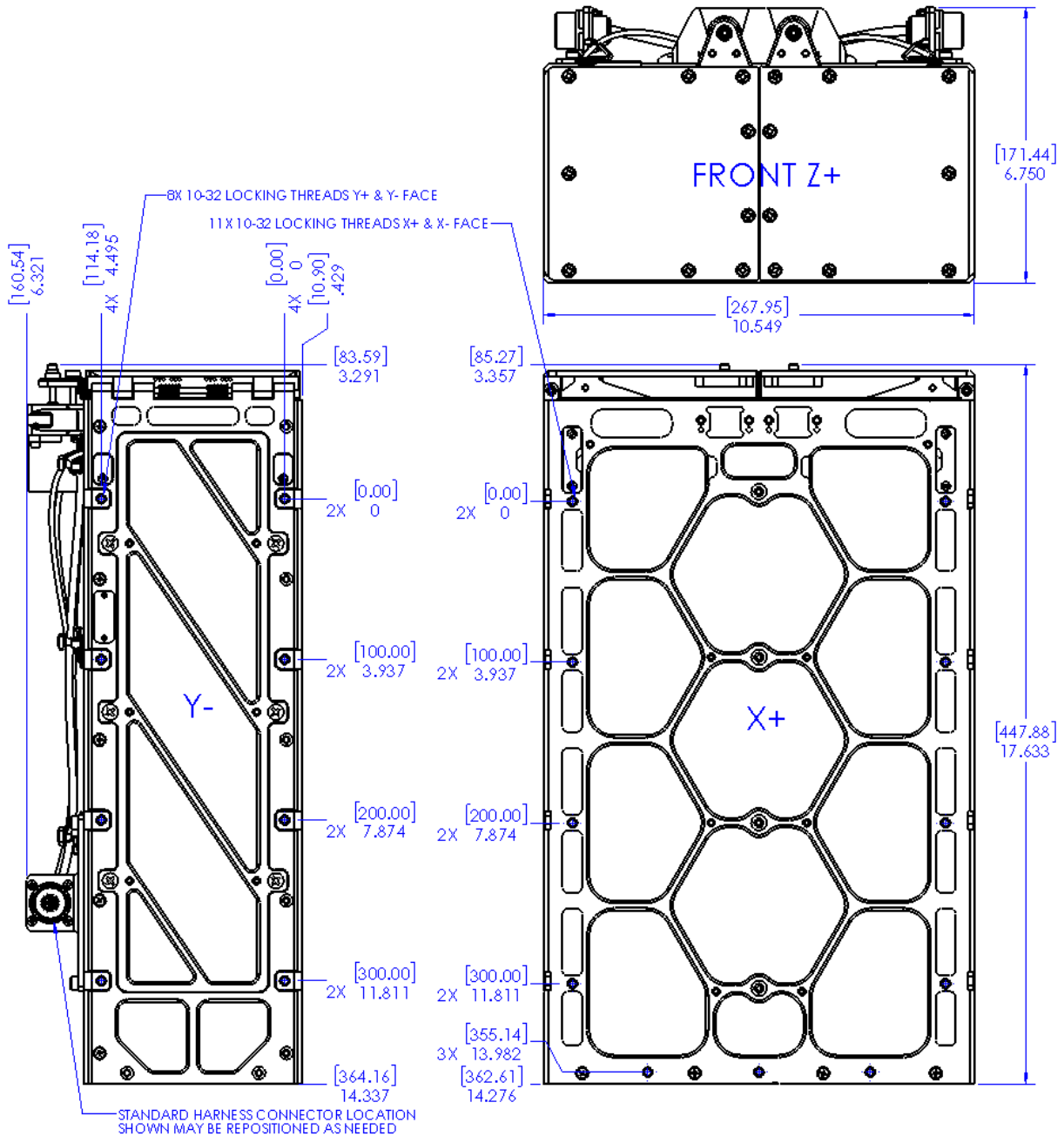

Figure 9: Dispenser profile and mass

### 5.2 MASS AND DIMENSIONS – QUADPACK

The Quadpack configuration consists of 2x standalone dispensers in any configuration, coupled to make a single deployment system. Connectors are facing the Y+/Y- face of the dispenser as shown. XCD Quadpack is compatible with the SpaceX RPUG Figure A-7 G Holes for direct mounting, see Figure 10.

Configuration	3U/3U	3U/6U	6U/6U
Empty Dispenser Mass (kg)	14.7	13.9	13.2

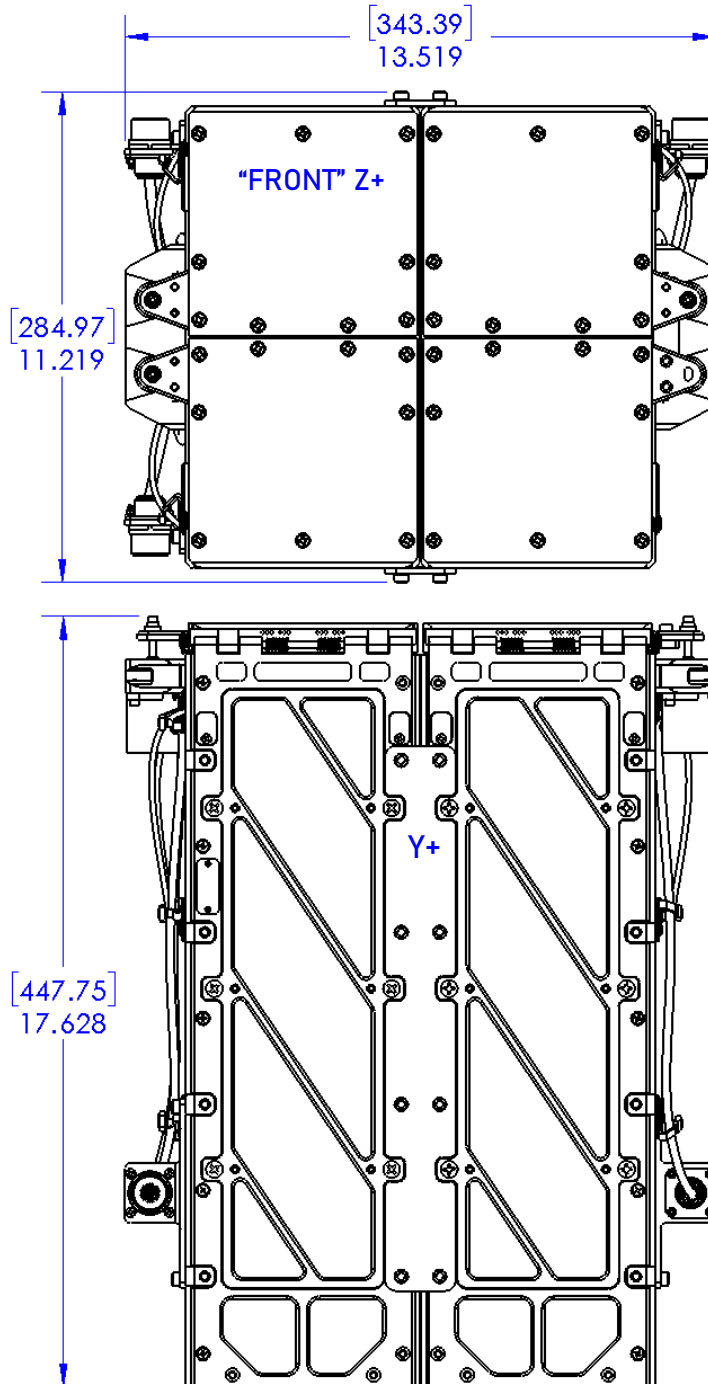
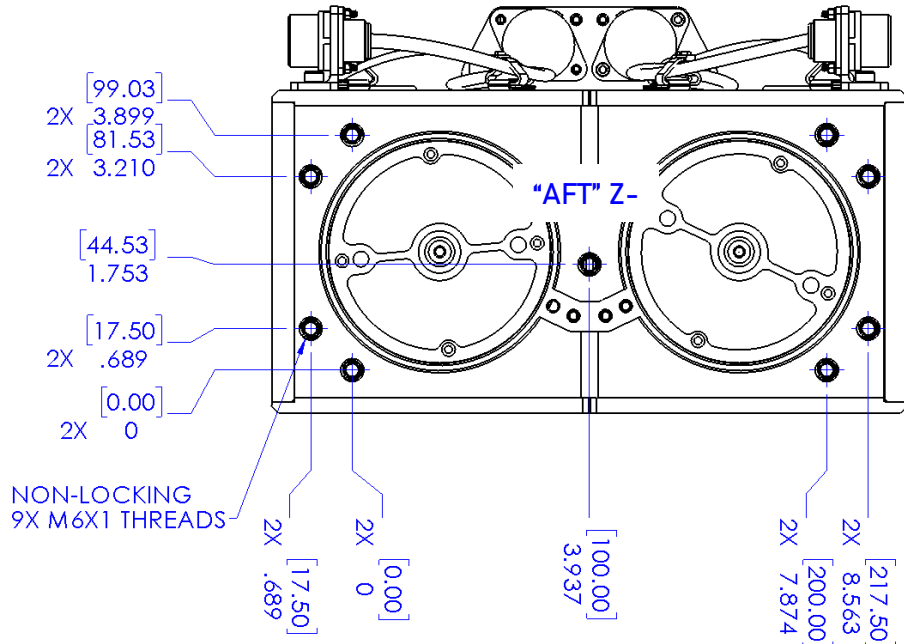

Figure 10: Dispenser profile and mass

**5.3 AFT MOUNTING INTERFACE - STANDALONE & QUADPACK**



**Figure 11: Standalone Dispenser Aft Profile**

Note that the Quadpack aft mounting pattern is designed to match and directly interface with the SpaceX RPUG pattern Figure A-7 "G" holes.

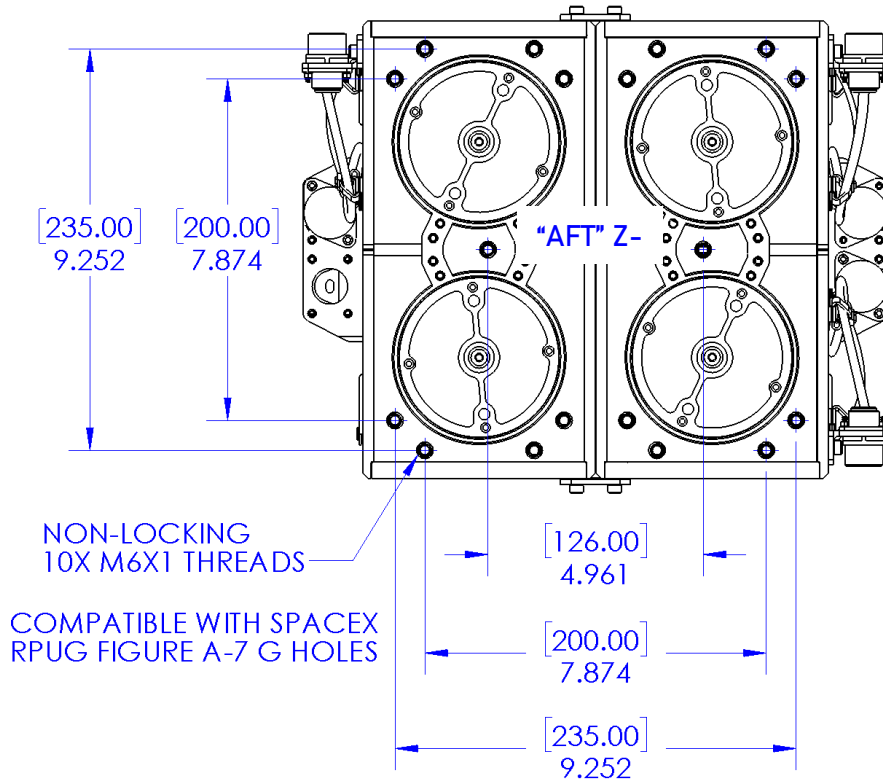

**Figure 12: Quadpack Dispenser Aft Profile**

## 5.4 FLIGHT ACCESS

The XCD has locations which can be used to connect to the satellite and stay connected throughout the flight up to the moment of deployment upon request.

## 5.5 CUSTOMER LOGOS

Customer logos may be added to the dispenser for promotional visibility as requested on doors or on sides, coordinate with XTERRA for details. Example locations are shown in Figure 13.

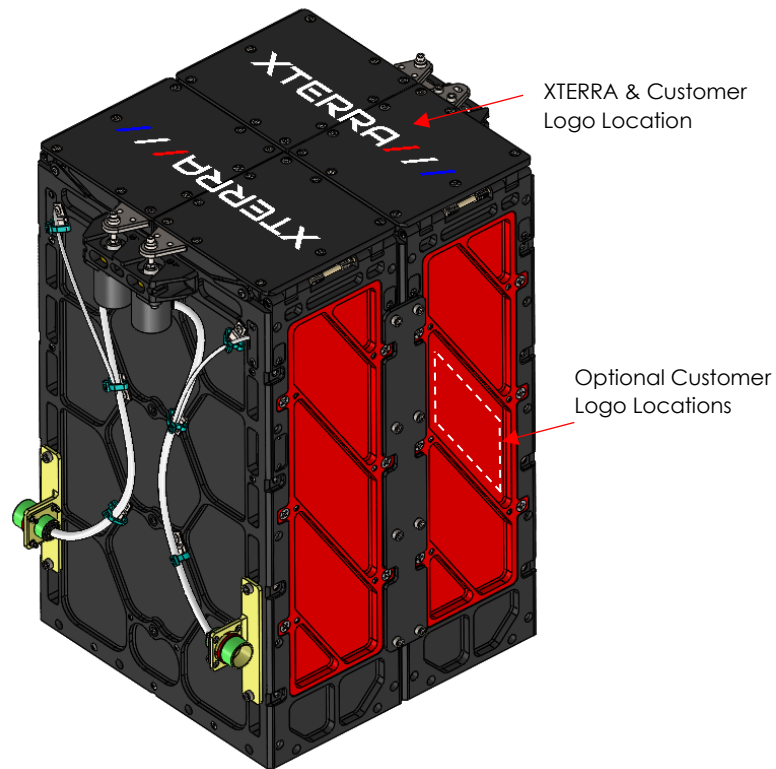

Figure 13: Customer Logo Locations

## 5.6 PRELOAD & RAIL INTERFACE

Once the payload is installed, the threaded puck is the mechanism by which preload is applied along the deployment axis. By clamping the satellite on the Z- and Z+ face, the loads on the satellite are dampened at high frequencies in lateral axis during exposure to the flight environment. This CalPoly [document](#) explains why this is and illustrates evidence for less high frequency energy being transferred to the satellite with this approach.

Importantly, this preload configuration greatly improves the rail to satellite interface during deployment by decreasing the risk of hanging/catching on rails that can be associated with systems that use “dynamic rails”. And because “dynamic rails” are not a part of this design approach, installing satellites into the dispenser is smooth and straightforward. Over 95% of our 350+ of our satellite deployments use these preload fundamentals, confirming its effectiveness and reliability.

## 5.7 CONVERSION SPACERS

Conversion spacers can be added to easily convert the XCD into a dispenser that accommodates any satellite length from 366mm to 113.5mm in length. When this option is purchased, spacer conversion kits include all required fasteners.

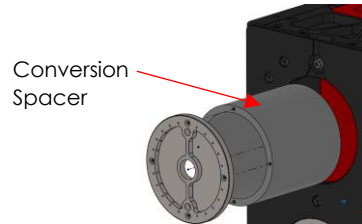

Figure 14: Spacers

## 5.8 DOOR FEATURES & RAPID RESET

Doors on the XCD are held in place by a single actuator. Once the actuator is activated, the doors open 95°-105° and are locked in place with redundant integrated spring-loaded kickstands to ensure that doors do not recontact the satellite while it is being deployed. The actuator is positioned to rapidly reset in minutes without removal of any major components. Users should ensure that all deployable appendages on CubeSats are constrained until after deployment, see section 4.3.

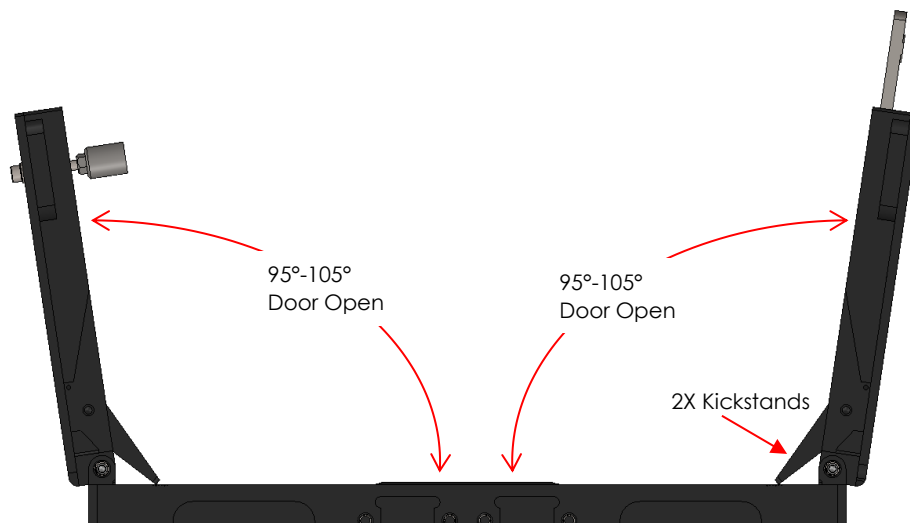

Figure 15: Independent Locking Doors



## 5.9 DISPENSER ACCESS AND CLAMSHELL

This feature allows satellites to be fully integrated and accessed with more available surface area than any dispenser on the market. 3U and 6U configurations can both take advantage of this.

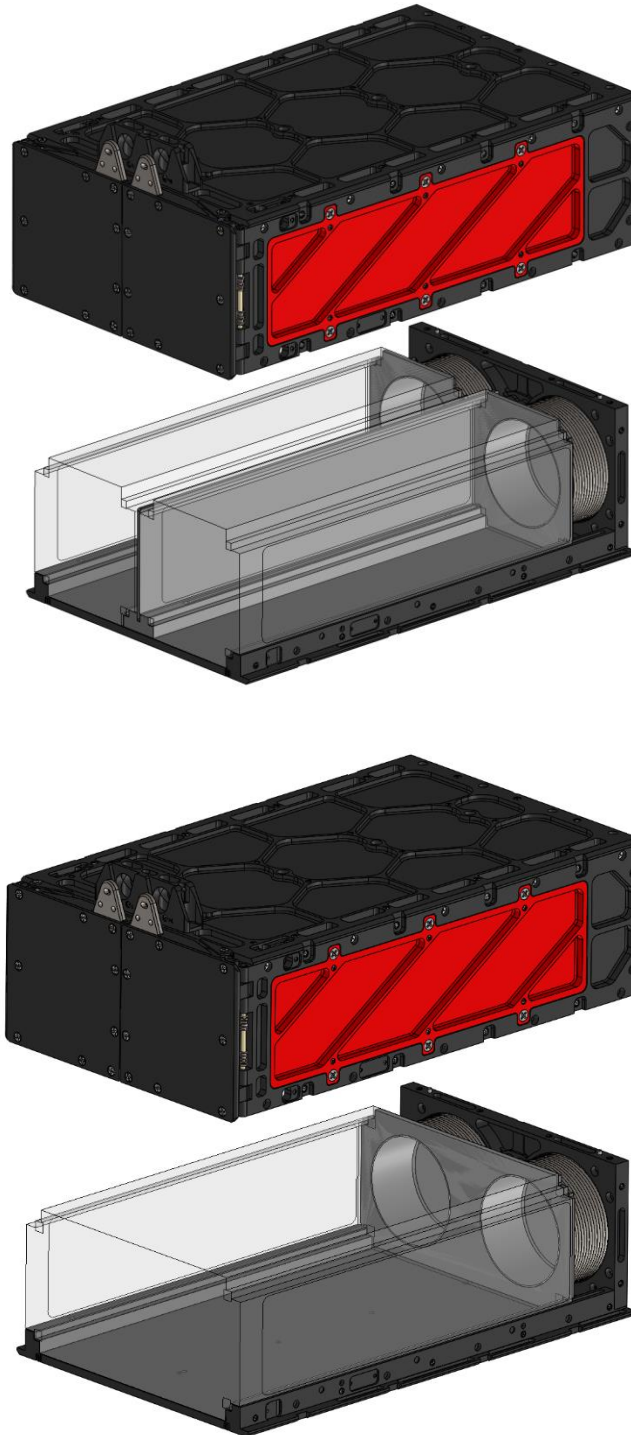

Figure 16: Clamshell

### 5.10 DEPLOYMENT CONFIRMATION

Once the pusher(s) reach the end of travel a signal is sent to confirm the satellite has been deployed. The switch is located in the rail section as shown in Figure 17. Doors are locked open with kickstands to ensure there will be no satellite recontact with the doors during deployment.

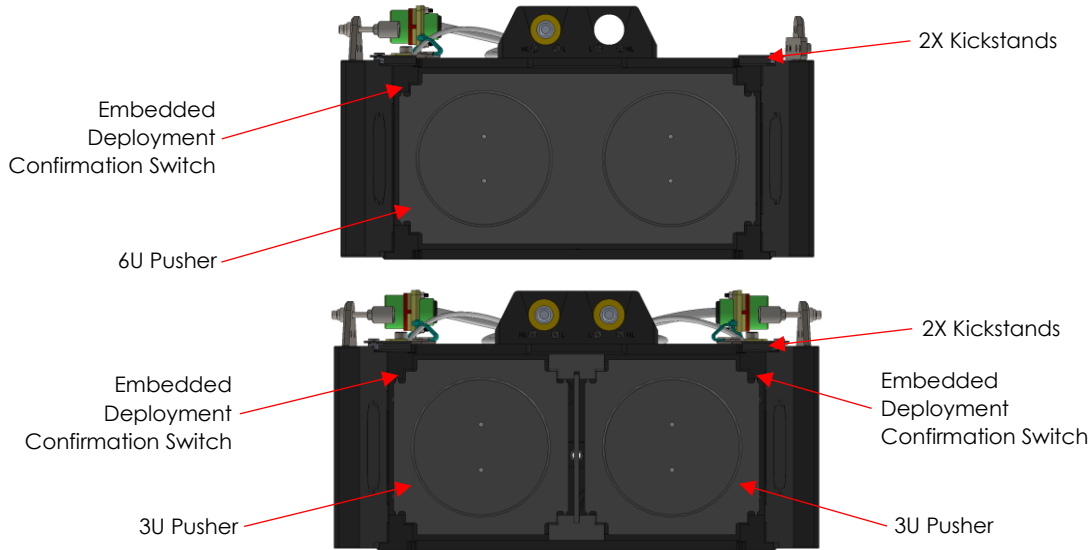

Figure 17: Deployment Confirmation Switch, 3U & 6U Config

### 5.11 DEPLOYMENT DYNAMICS

Deployment velocities shown in Figure 18 assume full pusher plate stroke in the tube with the mass specified (3U length 366mm and 6U length 366mm assumed). If payloads mass is outside of the range shown and/or partial stroke deployments are to be considered, custom deployment velocity analysis can be done upon request. Tip-off is largely dependent on the CG of the satellite but typically tip-off will be close to 5 deg/s or less.

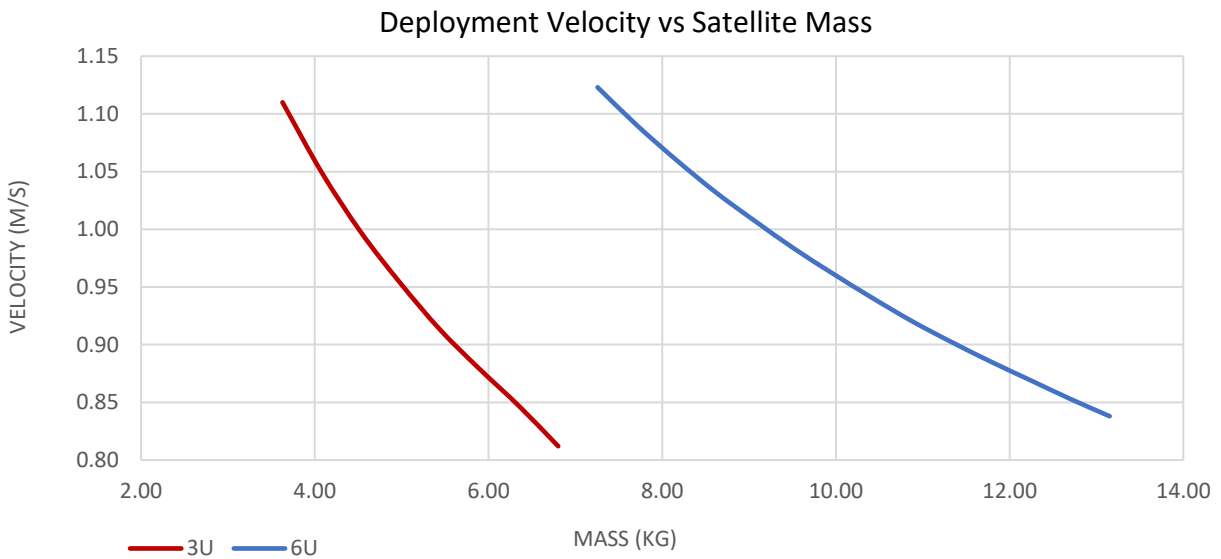
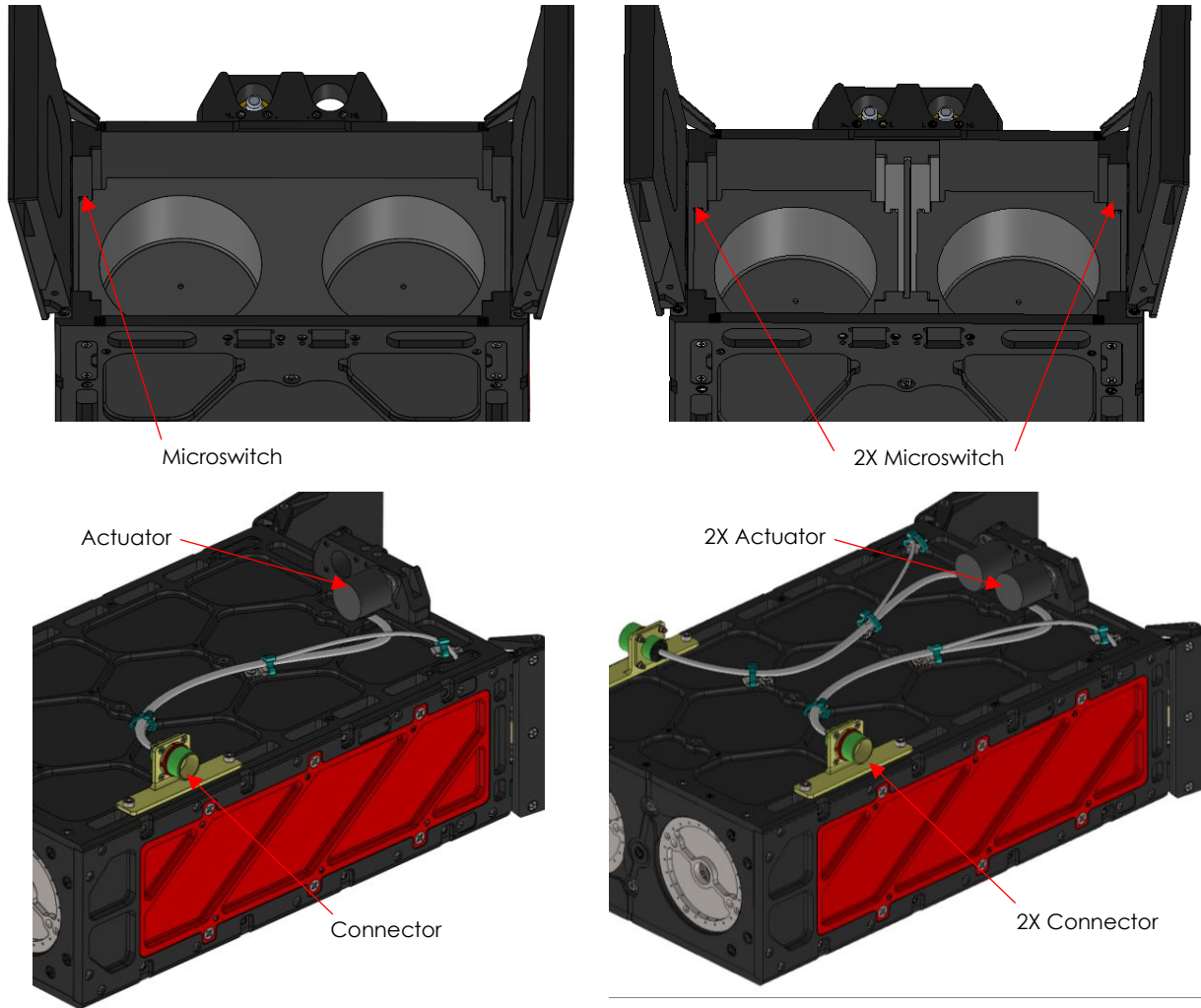

Figure 18: Deployment Velocity

## 6. ELECTRICAL CHARACTERISTICS

Three types of electrical components are used in the XCD Hybrid. A microswitch enables signal feedback to confirm deployment has been completed, an actuator is side mounted to open the doors when commanded, and a connector is connected to the microswitch and actuator. Data sheets for these components are available upon request after purchase of an XCD.



**Figure 19: Electrical Components**

A connector comes standard with the XCD, installed as shown in Figure 19, the location of the connector bracket can be adjusted if requested. Contact XTERRA if alternate connector is required. Two signals are sent through a common connector to ensure electrical reliability.

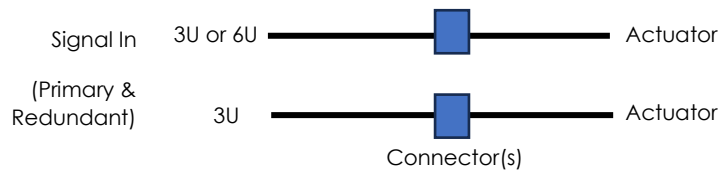

**Figure 20: Simple Circuit Design**

See more at <https://www.xterra.space/> and <https://www.arrowscitech.com/space-logistics>

# XTERRA // //

A division of Arrow Science and Technology LLC

XTERRA and Arrow Science and Technology, LLC are the copyright owners in this work, and no portion herein is to be copied, reproduced, or disseminated without their prior written approval.