

# XTERRA // //

A division of Arrow Science and Technology LLC

# XCD-12U/16U HYBRID USER GUIDE



XTD-100270  
Revision 1.2.1

XTERRA and Arrow Science and Technology, LLC are the copyright owners in this work, and no portion herein is to be copied, reproduced, or disseminated without their prior written approval.

## REVISIONS

Rev	By	Date	Description
1.0	TH	4-4-24	Initial Release
1.1	TH	1-15-25	Updated document to new standard configuration, entire document substantially overhauled.
1.2	TH	3-18-25	Section 4.1 clarified max volume under load. Added section 5.2 flight access.
1.2.1	TH	12-10-25	350 deploys updated to 400 on 1.0 & 5.6, updated language in 5.5, section 4.2 flatness updated

## AUTHORS

Name	Subject Matter	Contact Information
Tyler Holden	Electrical, Mechanical & Deployment	<a href="mailto:tholden@xterra.space">tholden@xterra.space</a>
Mark Rowley	Mechanical Support	<a href="mailto:mrowley@arrowscitech.com">mrowley@arrowscitech.com</a>

Note: Looking for custom tweaks to this system? Need a wholly custom deployment solution? Contact authors above.

## ADDITIONAL INFORMATION

Source	Description
Cal Poly State University	<a href="#">Launch Isolation Vibration for CubeSat Dispenser</a>
XTERRA	<a href="https://www.xterra.space/">https://www.xterra.space/</a>

## ACRONYM DEFINITIONS

Acronym	Description
XCD	XTERRA CubeSat Dispenser
CG	Center of Gravity

## NEED A RIDE TO SPACE?

Name	Subject Matter	Contact Information
Marcia Hodge	Rideshare	<a href="mailto:mhodge@arrowscitech.com">mhodge@arrowscitech.com</a>
Space Logistics		<a href="https://www.arrowscitech.com/space-logistics">https://www.arrowscitech.com/space-logistics</a>

Note: This document is a work in progress and additional information will be added as it becomes available. Feedback sent to the authors is welcomed.

# TABLE OF CONTENTS

- 1. INTRODUCTION ..... 4
- 2. SYSTEM OVERVIEW ..... 5
- 3. UNIQUE DISPENSER FEATURES ..... 6
  - 3.1 CUSTOM SATELLITE LENGTHS ..... 6
  - 3.2 LARGE ACCESS PANELS ..... 6
- 4. SATELLITE FUNDAMENTALS .....7
  - 4.1 FORMATS AND DIMENSIONS ..... 7
  - 4.2 RAILS & ACCESS PANELS..... 8
  - 4.3 DEPLOYABLE APPENDAGES ..... 8
  - 4.4 CG OFFSET..... 8
  - 4.5 INHIBIT/ACTIVATION SWITCHES ..... 9
- 5. DISPENSER FUNDAMENTALS ..... 10
  - 5.1 MASS, DIMENSIONS, AND MOUNTING INTERFACES.....10
  - 5.2 FLIGHT ACCESS ..... 11
  - 5.3 CUSTOMER LOGOS ..... 11
  - 5.4 PRELOAD ..... 12
  - 5.5 CONVERSION SPACERS ..... 12
  - 5.6 DOOR FEATURES & RAPID RESET..... 12
  - 5.7 DEPLOYMENT CONFIRMATION ..... 13
  - 5.8 DEPLOYMENT DYNAMICS..... 13
- 6. ELECTRICAL CHARACTERISTICS ..... 14

# 1. INTRODUCTION

XTERRA has designed and/or manufactured hardware that has successfully deployed over 400 satellites, has developed over 20 unique designs, and has been designing and building space hardware [since 2012](#). We design and manufacture cutting edge, electro-mechanical devices that change what you can do in space. Building on a legacy of success, the XTERRA CubeSat Dispenser (XCD) redefines deployment hardware with its flight proven, American-made design. With our patent-pending modular approach to CubeSat dispenser design, the XCD is designed to reduce costs, cut lead times, and remove pain points from traditional CubeSat dispenser offerings, while retaining the highest quality standards.



Users often need to purchase 12U or 16U dispensers separately to cover potential dimensional or manifesting changes that can occur prior to flight. This problem is exacerbated by the often-tight schedules typical of launch date driven projects which may result in a change to the manifest at the last second. Our system allows us to rapidly convert to custom length satellites you may want to fly, anything between 227mm and 454mm. For example, the XCD can be converted between 12U and 16U satellite compatibility in about an hour, drastically decreasing operational complexity. No more waiting months for a vendor to get a legacy dispenser converted or ordering a new dispenser at the last second.



The XCD is rapidly resettable, offers the most integrated satellite access on the market, allows rapid convertibility between different form factors, all supported by the reliable expertise that ensures customers' success every time.

No dispenser on the market rivals the flexibility or convenience of the XCD.

## 2. SYSTEM OVERVIEW

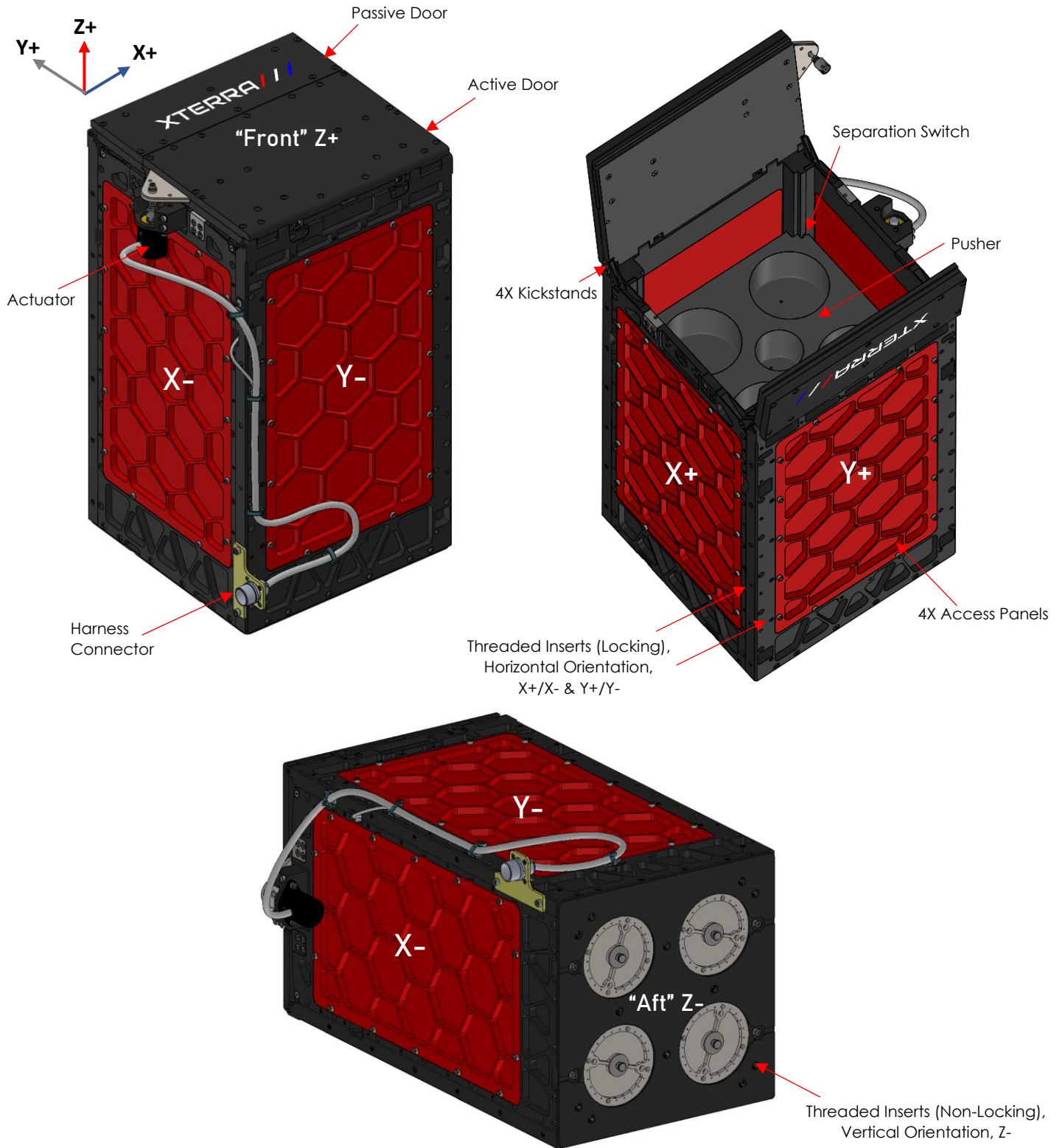

Figure 1: XCD-16U Hybrid Overview



## 3. UNIQUE DISPENSER FEATURES

### 3.1 CUSTOM SATELLITE LENGTHS

Custom satellite spacers to accommodate standard and non-standard payload lengths have been radically simplified using the XCD. This new spacer design allows for a very short lead time spacer at a tiny fraction of the cost of a traditional solution. While the spacers are installed, the dispenser components interfacing with the satellite do not change regardless of the satellite length. The result of this feature is this dispenser can be rapidly converted from a 16U compatible tube to a 12U compatible tube in about an hour, or any length satellite between 227mm and 454mm. Inform XTERRA of your satellite length and we will deliver the dispenser preconfigured appropriately.

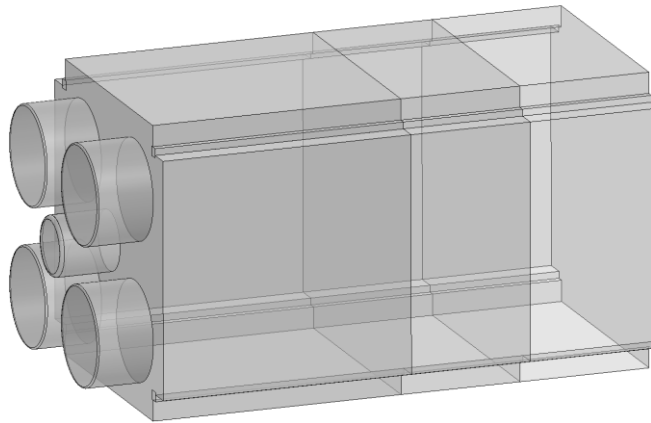

Figure 2: Custom Lengths

### 3.2 LARGE ACCESS PANELS

Users of CubeSat dispensers often find they need to access particular areas of a satellite once it's integrated in the dispenser. This is traditionally achieved using multiple medium or small access panels, which are often insufficient to provide access to the locations users would prefer on the satellite, such as for RBF pin removal or data connections. The XCD offers the highest surface area access to the payload compared to any other dispenser on the market. Panels on all four sides maximize flexibility and usability.

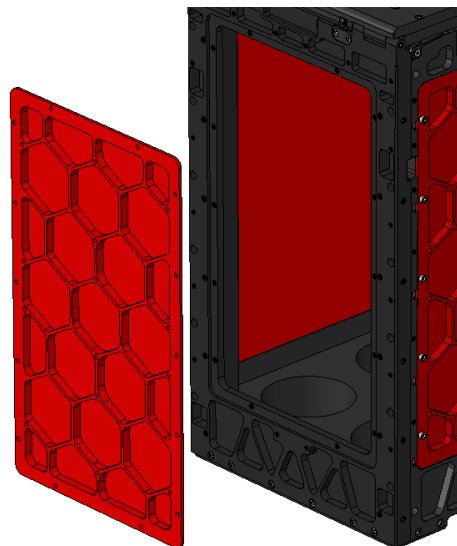

Figure 3: Access Panels

## 4. SATELLITE FUNDAMENTALS

### 4.1 FORMATS AND DIMENSIONS

Maximum volume, access panel location, and optional “tuna cans” shown in Figures 4 & 5. The satellite shall not exceed the max volume shown in Figure 4 under dynamic testing and launch loads. Dimensions are in [mm] and inches.

Satellite Format	8U	12U	16U
Mass (kg) Max	16	*28	*32
Rail to Rail Length (mm) Z <sub>axis</sub>	227 Min	340.5	454 Max

\*Mass that exceed values shown may be considered, contact XTERRA for details

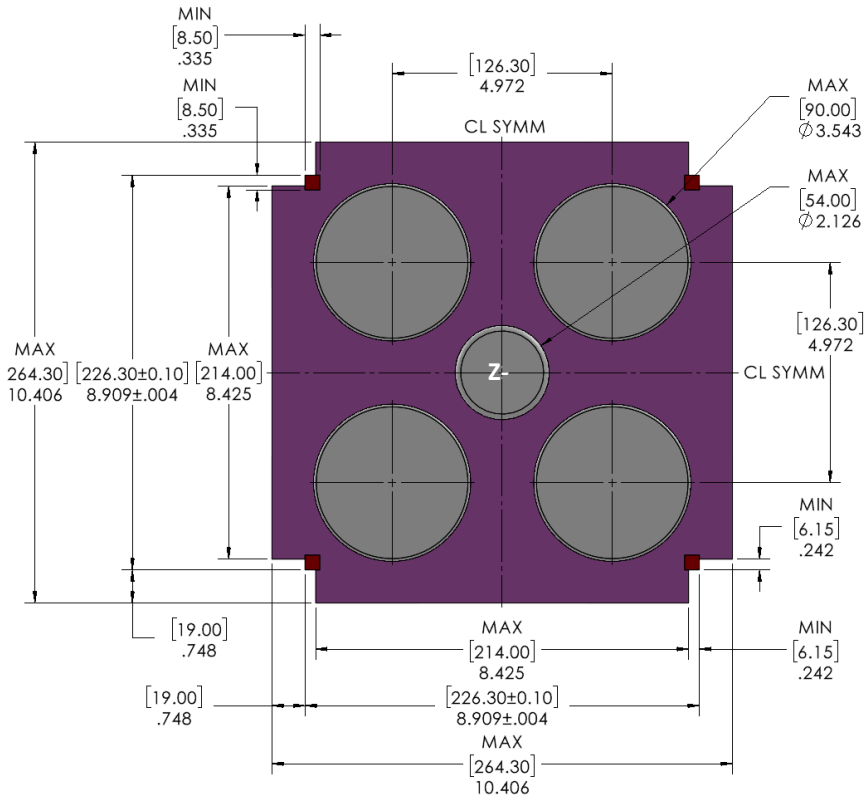
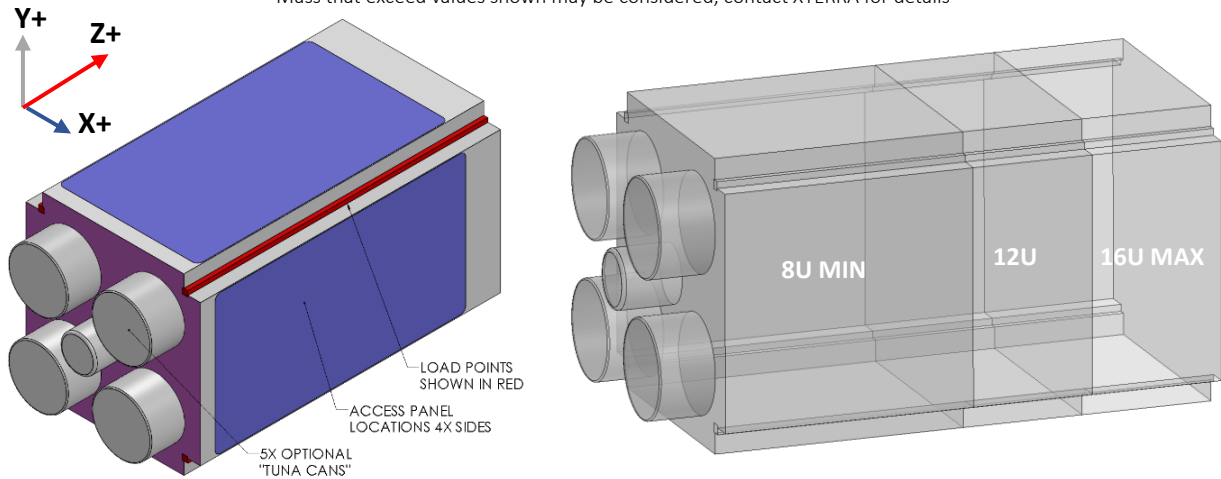

Figure 4: Satellite Volume

### 4.2 RAILS & ACCESS PANELS

CubeSats must have rails as shown in Figure 4 & 5 in red. These will directly interface with the dispenser rails during launch and will be the guiding surface during deployment. Noncontinuous rails may be acceptable pending an XTERRA review. Each CubeSat rail shall have a minimum width as shown in Figure 4.

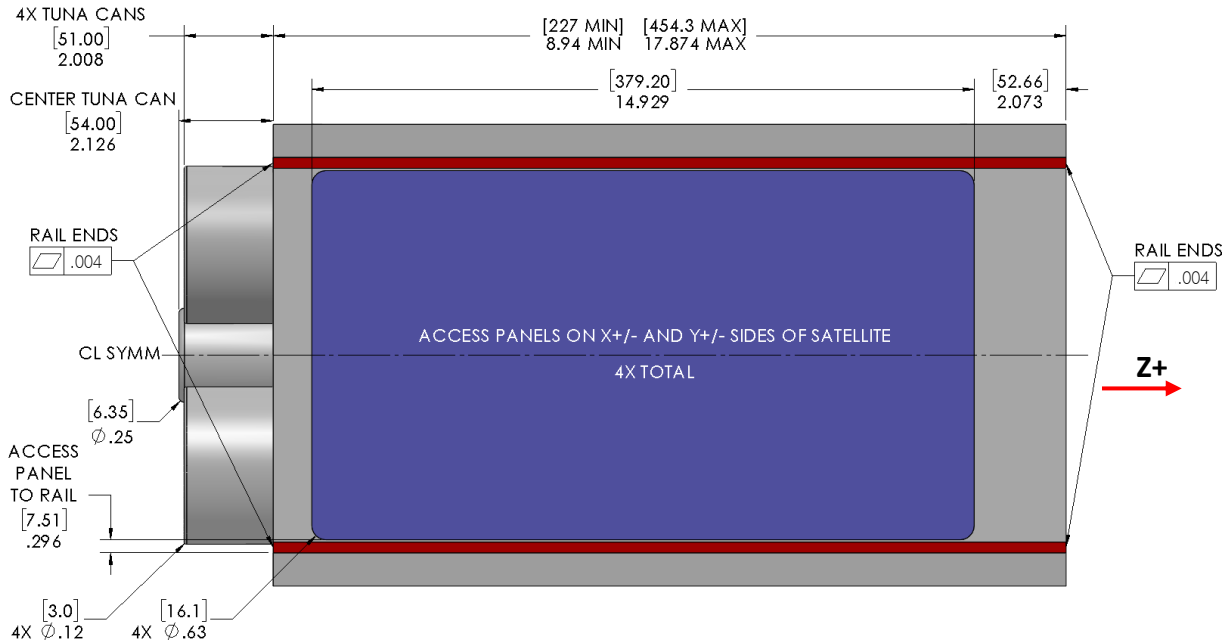

Figure 5: Rail profile, Volume Continued, Access Panel Locations

### 4.3 DEPLOYABLE APPENDAGES

It is highly recommended that any deployable satellite appendages are constrained through launch and during deployment. Appendages can be constrained by the dispenser during launch and deployment (if launch vehicle allows), but fit checks are highly recommended to ensure a reliable deployment using this method and an XTERRA review will be necessary.

### 4.4 CG OFFSET

It is recommended that the offset from the geometrical center of the satellite and the CG is limited to the values shown below. Higher values will result in greater tipoff during deployment.

Satellite	X-axis (mm)	Y-axis (mm)	Z-axis (mm)
8U	+/-45	+/-45	+/-45
12U	+/-45	+/-45	+/-67.5
16U	+/-45	+/-45	+/-90

Note: Offset scales linearly in the Z-axis with regards to satellite lengths between 227mm and 454mm.

Note: Satellites with offsets that exceed the values above are compatible with this dispenser but must be reviewed.



### 4.5 INHIBIT/ACTIVATION SWITCHES

Switches, which activate the satellite after deployment, may be positioned anywhere compression is guaranteed between the satellite and the dispenser. Typically, there are switches on the ends of the rails in the Z axis or on the Z faces of the satellite, activation travel recommended .75mm MIN. Switches can also be along sides of the rails in the X or Y axis. The X & Y axis switches must have enough travel to guarantee switch compression, 1.5mm travel minimum. See Figure 6. A simplified dispenser CAD model can be provided for a digital fit check to ensure that switches will compress as desired.

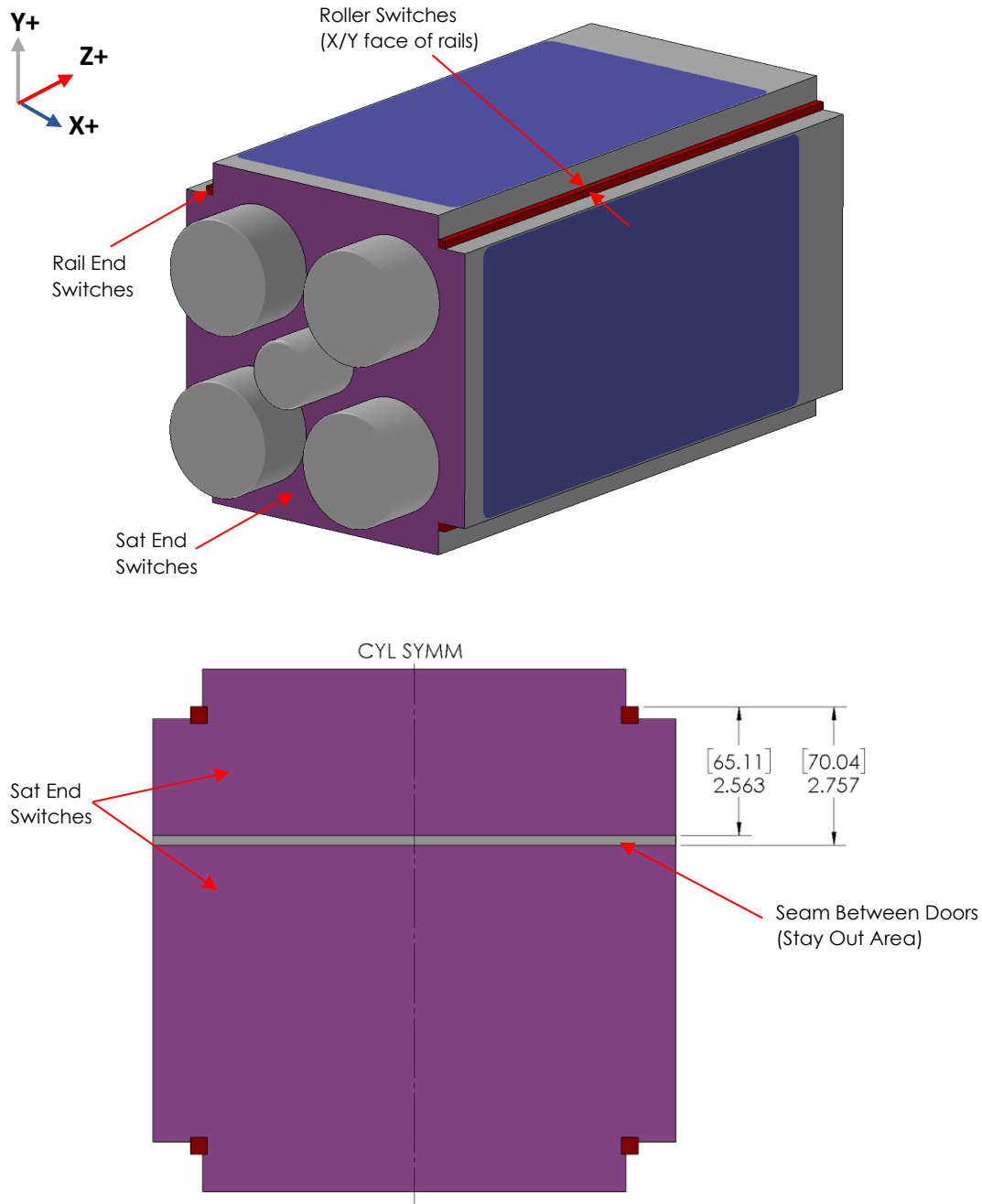

**Figure 6: Activation Switch Locations**

## 5. DISPENSER FUNDAMENTALS

### 5.1 MASS, DIMENSIONS, AND MOUNTING INTERFACES

External dimensions of the dispenser are the same for any satellite configuration. Y+ face and Y- face threads are mirrored on both sides. X- face and X+ face threaded features are mirrored on both sides. These are for horizontal mounting. Note that harnessing can be moved to accommodate mounting. Figure 7 & 8 dimensions are in [millimeters] and inches.

Configuration	16U	
Empty Dispenser Mass (kg)	17.91	Other Masses are Sat Length Dependant

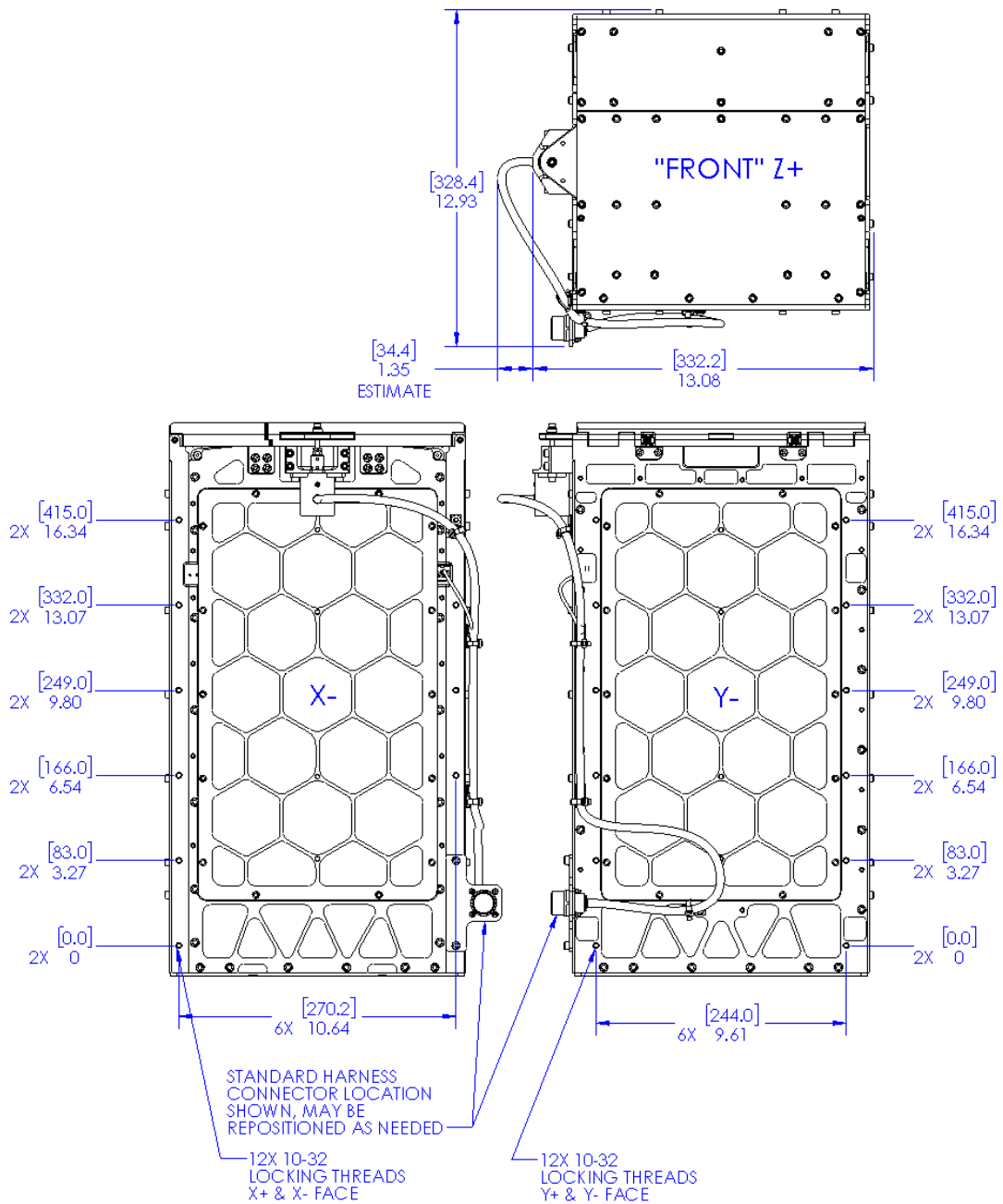

**Figure 7: Dispenser Profile**

M6X1 aft threaded inserts are located on the Z- face for mounting. This pattern matches the SpaceX RPUG pattern Figure A-7 "G" holes.

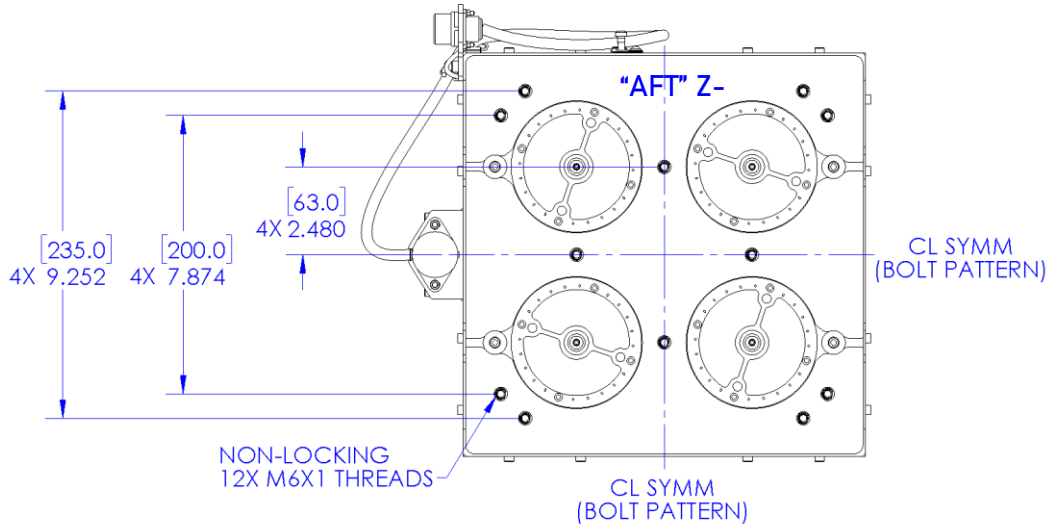

Figure 8: Dispenser Aft Profile

### 5.2 FLIGHT ACCESS

The XCD has locations which can be used to connect to the satellite and stay connected throughout the flight up to the moment of deployment upon request.

### 5.3 CUSTOMER LOGOS

Customer logos may be added to the dispenser for promotional visibility as requested, coordinate with XTERRA for details. Example locations are shown in Figure 9.

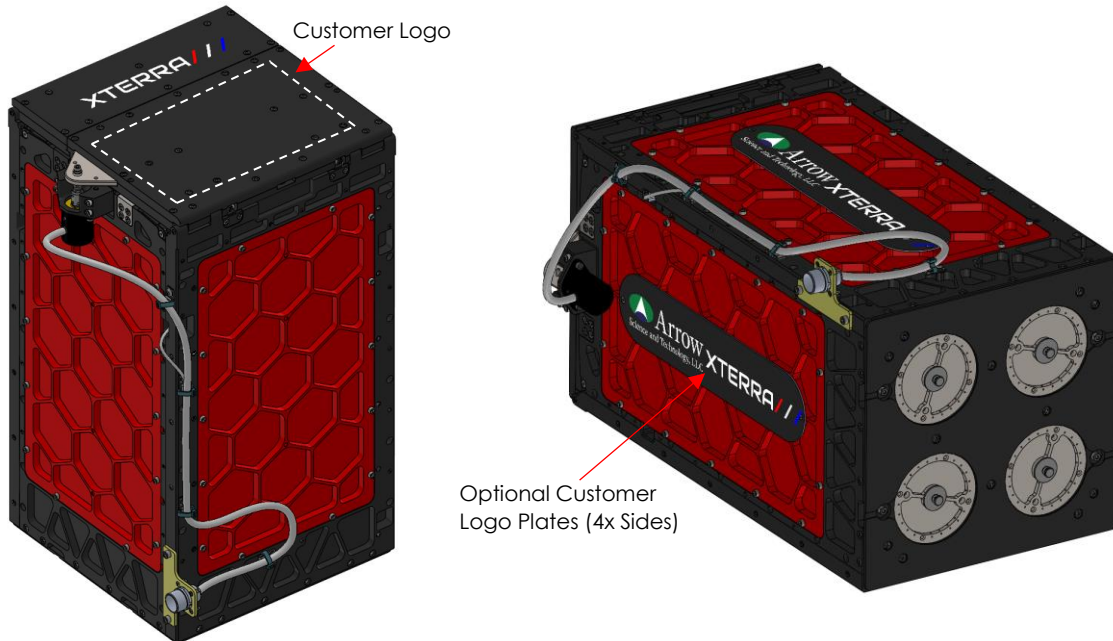

Figure 9: Customer Logo Locations

### 5.4 PRELOAD & RAIL INTERFACE

Once the payload is installed, the threaded puck is the mechanism by which preload is applied along the deployment axis. By clamping the satellite on the Z- and Z+ face, the loads on the satellite are dampened at high frequencies in lateral axis during exposure to the flight environment. This CalPoly [document](#) explains why this is and illustrates evidence for less high frequency energy being transferred to the satellite with this approach.

Importantly, this preload configuration greatly improves the rail to satellite interface during deployment by decreasing the risk of hanging/catching on rails that can be associated with systems that use “dynamic rails”. And because “dynamic rails” are not a part of this design approach, installing satellites into the dispenser is smooth and straightforward. Over 95% of our 400+ satellite deployments use these preload fundamentals, confirming its effectiveness and reliability.

### 5.5 CONVERSION SPACERS

4x conversion spacers can be added to easily convert the XCD into a dispenser that accommodates any satellite length from 454mm to 227mm in length. When this option is used, the interface between the satellite and the pusher plate remains the same, cutting down on complexity when using in tube spacers.

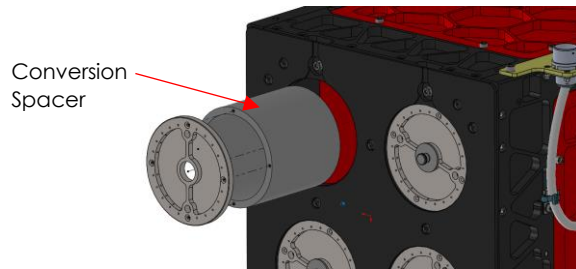
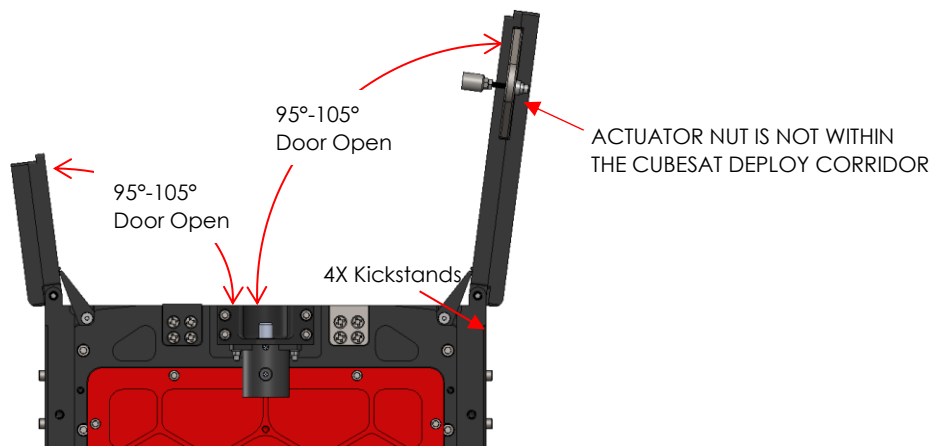

Figure 10: Spacers

### 5.6 DOOR FEATURES & RAPID RESET

Doors on the XCD are held in place by a single actuator. Once the actuator is activated, the doors open 95°-105° and are locked in place with redundant integrated spring-loaded kickstands to ensure that doors do not recontact the satellite while it is being deployed. The actuator is positioned to rapidly reset in minutes without removal of any major components. Users should ensure that all deployable appendages on CubeSats are constrained until after deployment, see section 4.3.



**Figure 11: Independent Locking Doors**

**5.7 DEPLOYMENT CONFIRMATION**

Once the pusher reaches the end of its travel a signal is sent to confirm the satellite has been deployed. The switch is located in the rail section as shown in Figure 12.

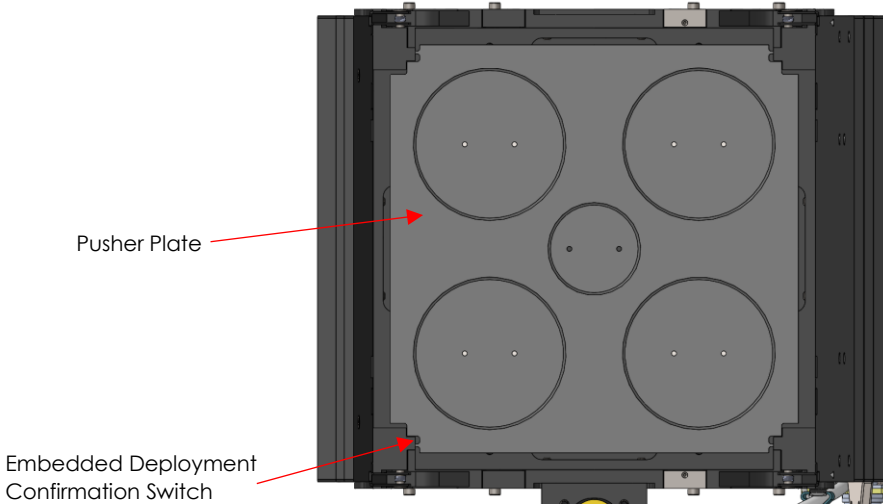

**Figure 12: Deployment Confirmation Switch**

**5.8 DEPLOYMENT DYNAMICS**

Deployment velocities shown in Figure 13 assume full pusher plate stroke in the tube with the mass specified (12U length 366mm and 16U length 454mm assumed). If payloads mass is outside of the range shown and/or partial stroke deployments are to be considered, custom deployment velocity analysis can be done upon request. Tip-off is largely dependent on the CG of the satellite but typically tip-off will be close to 5 deg/s or less.

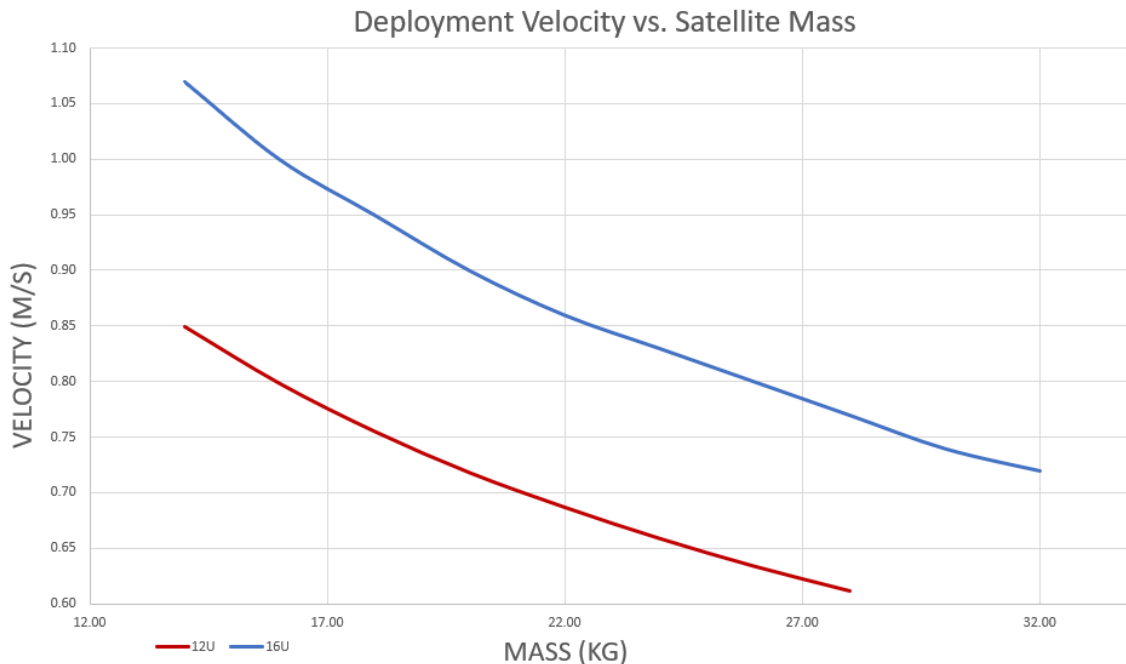

**Figure 13: Deployment Velocity**

## 6. ELECTRICAL CHARACTERISTICS

Three types of electrical components are used in the XCD-16U Hybrid. A microswitch enables signal feedback to confirm deployment has been completed, an actuator is side mounted to open the doors when commanded, and a connector is connected to the microswitch and actuator. Data sheets for these components are available upon request after purchase of an XCD.

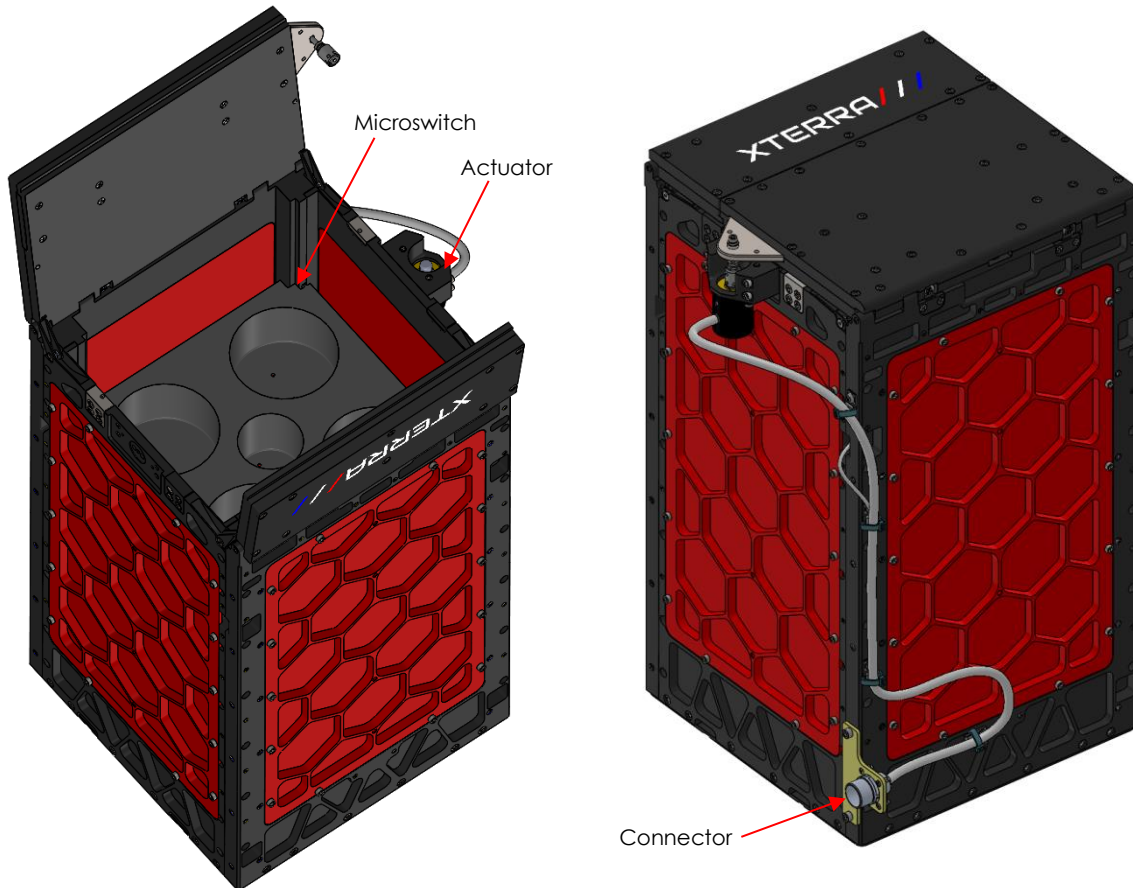

**Figure 14: Electrical Components**

A connector comes standard with the XCD, installed as shown in Figure 14, the location of the connector bracket can be adjusted if requested. Contact XTERRA if alternate connector is required. Two signals are sent through a common connector to ensure electrical reliability.

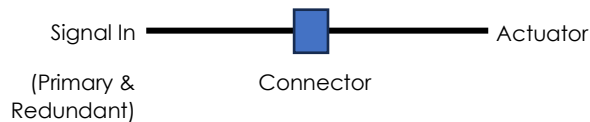

**Figure 15: Simple Circuit Diagram**





Over 400 deployments and counting